



Guide



Product Range Guide

Solutions for indoor plumbing

Water distribution, heating, underfloor heating, indoor waste line systems, roof drainage



An Orbia business.

2024

Comprehensive solutions for indoor plumbing



Wavin Comfia



Wavin PP-R



Wavin Sentio

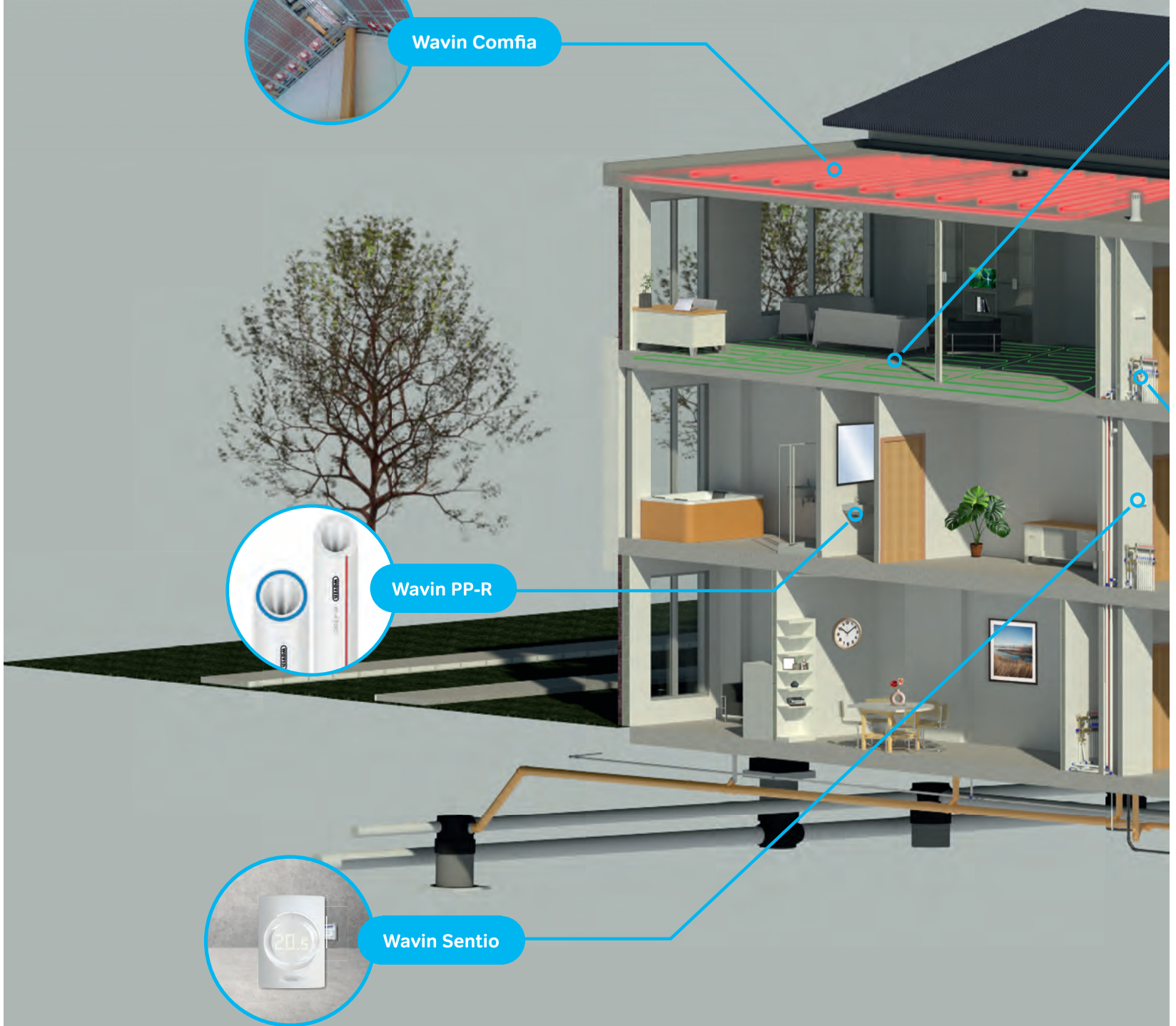

Wavin Underfloor Heating



Wavin Comfia

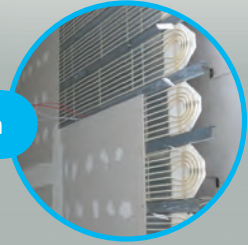

Wavin AS+



Wavin SiTech+



Wavin Tigris K5/M5



Content

References	5
-------------------------	---

Water, heating and UFH distribution

Wavin PP-RCT	6
Wavin Interconnection Fittings	10
Wavin Tigris	12
Wavin Hep₂O	18

Interior gravity waste line systems

Wavin Manifolds	22
Wavin SiTech+	24
Wavin AS+	28
Wavin PVC-U	30
Wavin Hep_vO	32
Wavin QuickStream	36
Wavin Kanion	40

References



Arabian Ranches III - a collection of spacious residential villas, Wavin PP-RCT

Dubai, UAE



National Theater, Wavin PP-RCT, Wavin SiTech+

Prague, Czech Republic



General sanitation, Wavin PP-R

Male, Maldives



Project SECRET GARDEN, Wavin SiTech+

Tirana, Albania



Housing complex Delijorgji, Wavin Tigris MP

Tirana, Albania



Port De La Mer by Meraas, Wavin SiTech+

Dubai, UAE

Wavin Turkey PP-R/PP-RCT System



Wavin PP-R/PP-RCT Pipes

All mono layer and multilayer pipes made from TYPE 3 PP-R or TYPE 4 PP-RCT raw material are in sizes between 20 to 125mm. Different color options are available.

Wavin PP-R Fittings

All full plastic or metal inserted fittings are made of Type3 PPR raw material and can be used together with PP-R or PP-RCT pipes. Fitting sizes are between 20-125mm. Different color options are available.



Characteristics of the System

The Wavin PP-R/PP-RCT system is a polyfusion welded system made of polypropylene (PPR, PP-RCT). The system includes all-plastic and multi-layer pipes and a wide range of all-plastic or combined (plastic, metal) pipe fittings. Also includes a vast selection of accessories and assembly tools.

Application

Wavin PP-R/PP-RCT can be used for piping in residential, administrative and cultural buildings as well as for industrial or agricultural piping. Wavin PP-R/PP-RCT is designed for transporting cold and hot water, for underfloor heating, and, if these assembly instructions are followed, even for central heating. Wavin PP-R/PP-RCT can also be used to transport air, cooling water and for air-conditioning. Using the piping's chemical resistance and other properties for transporting other liquids, gases or solids requires individual assessment for each use case. The manufacturer needs to assess the suitability of the piping if the hot water conducted through it is chemically disinfected. Permanent disinfection of hot water using chlorine dioxide shortens the life of the system and is therefore not recommended.

Product Portfolio and Features

- ⊙ Products are produced in Wavin' s Turkey factory in Adana according to EN ISO 15874 standard.
- ⊙ Different type of pipes for different application areas...
Mono layer PP-R and PP-RCT Pipes for hot&cold water applications and Multilayer pipes for heating applications.
- ⊙ Multilayer pipes are made of PP-R and PP-RCT raw material with different middle layer fiber composition...
- ⊙ All plastic fittings are ready for perfect welding performances like coupler, bends, tees, manifolds, caps and clips.
- ⊙ Fittings with inserts are ready to use with metallic installation parts like valves, manifolds, unions, pumps and radiators.
- ⊙ Metal inserts which are in contact with drinking water are non-coated brass inserts.
- ⊙ Different color options for different markets: White, Green and Grey.
- ⊙ International certificates: DVGW, AENOR, CSTB, WRAS.



Nickel Plated



Non-Plated



Advantages of PPR-PPRCT Pipe Systems

- ① Durable, robust and rigid system
- ① Lightweight products, easy to carry or install. Light bracketing.
- ① Simple tools and easy installation.
- ① Trusted welding connection, no seal. Safe system.
- ① No corrosion risk and high resistance for chemicals.
- ① High temperature resistance: 95°C short term water temperature.
- ① Long service life. 50 years and more...
- ① Rich product portfolio and high number of fittings due to flexibility of production.
- ① Design freedom for engineers and installers according to enriched portfolio.
- ① High contribution to the circular economy with ease of recycle.
- ① Cost effective performance product.
- ① No bore reduction – Less pressure losses.
- ① Most widely used plastic H&C system all over the world.

Additional Advantages of Multilayer Piping System

All pipes will be extended together with temperatures differences. But the thermal expansion of the pipes will be different according to pipe composition. Thanks to multilayer pipes, pipe expansion can be easily limited.

Multilayer pipes are made of three layer. PP-R or PP-RCT on both inner and outer layer and a special compound of material in the middle of the pipe. This middle layer brings less expansion property to the pipe. Multilayer pipes deliver 3x times better thermal expansion.

“Compound reinforcement brings new features to the pipe.”



Glass Fiber Reinforced Multilayer Pipe

- ① High tensile strength
- ① Dimensional stability
- ① Good thermal conductivity
- ① Readily material for production
- ① Easy to install, no shaving

Technical Parameters

Wavin PP-R Monolayer



Wavin PP-RCT Monolayer



Wavin PP-R Glass Fiber Multilayer



Wavin PP-RCT Glass Fiber Multilayer



Dimensions	Size Group SDR	Operating Pressure Rating (bars)*	Operating Conditions (bars)*	Material	Application Areas	Thermal Expansion Coefficient (mm/mK)
Ø 20 – 125 mm	S5 - S3,2 - S2,5 SDR10 - SDR7,4 - SDR6	PN10 - PN16 - PN20 @20°C, 50 years	6,4 - 10,2 - 12,9 @60°C, 50 years	Type 3 - Monolayer PP-R	Cold Water	0,15
Ø 20 – 125 mm	S4 SDR9	PN22 @20°C, 50 years	10,2 @60°C, 50 years	Type 4 - Monolayer PP-RCT	Cold Water	0,15
Ø 20 – 125 mm	S3,2 - S2,5 SDR7,4 - SDR6	PN20 - PN25 @20°C, 50 years	10,2 - 12,9 @60°C, 50 years	Type 3 - Multilayer PP-R PP-R/Glass Fiber/PP-R	Hot Water	0,035
Ø 20 – 125 mm	S3,2 SDR7,4	PN25 @20°C, 50 years	12,8 @60°C, 50 years	Type 4 - Multilayer PP-RCT PP-RCT/Glass Fiber/PP-RCT	Hot Water	0,035

*Operating conditions belongs to PP-R & PP-RCT service life graphics with safety factor 1,5.

Features of Glass Fiber Reinforced PP-R Multilayer Composite Pipes

- ① Consists of PPR inner and outer layers and a special mixture of Glass Fiber (GF) PP middle layer.
- ② The glass fiber reinforced (GFR) layer within the two PPR layers reduces the pipe's thermal extension. The GFR pipes can provide all performance features which solid wall pipe have. Service life and conditions may be checked from relevant tables (Table2) due to operating pressure and temperature.
- ③ Glass fiber reinforced (GFR) pipe has similar thermal expansion coefficient with aluminium stabil PPR pipe has. (Graphic 1)
- ④ The mixture of Polypropylene and Glass Fiber minimizes elongation from heat. That is why installation requires less bracketing and fixing points.
- ⑤ Alternative solution to conventional pipe systems suitable for e.g., cooling and air conditioning systems, sanitary installations, industrial pipeline construction and rainwater utilization systems.

Why choose Wavin Glass Fiber Reinforced PP-R Multilayer Composite Pipes?

- 1 Easy to install
- 2 Saving on Time
- 3 Cost-Efficient
- 4 Less Expansion
- 5 Compliance to European Standards
- 6 Reliable Technology High Quality

Graphic 1: Elongation of various PP pipes

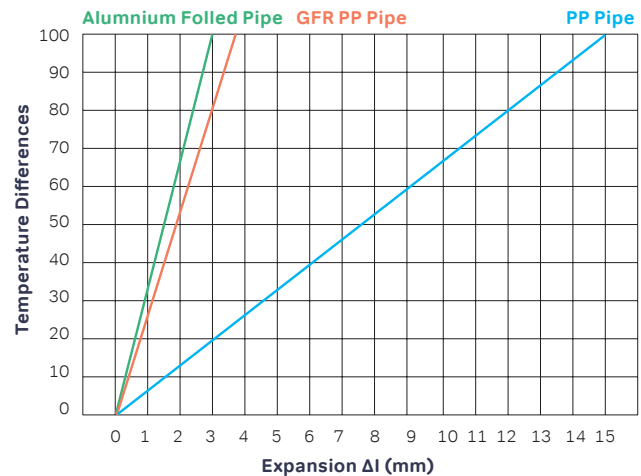

Complied Standards	DIN 8077/8078, EN 15874-2, TS 13715	
Pressure Class	SDR 7,4	SDR 6
Diameter Range	20-125	20-125

Advantages of GFR Pipes:

- ① GFR PPR pipe elongates less during the heat changes.
- ② Unlike aluminium foiled pipes; there is no need to shave the end of the pipe. The welding process should begin directly. This provides ease of installation.
- ③ Can be easily used for hot water systems.
- ④ It is a lighter product compared to metal pipes. Therefore, it is easy to carry and install. The linear coefficient of thermal expansion value is small. (0,035mm/WmK). Less bracketing is necessary compared to solid wall pipes.
- ⑤ Due to the glass fiber reinforced layer, thermal conductivity is smaller than solid wall pipe. That is why less insulation will be enough.
- ⑥ It does not cause a change in the color, smell or the taste of water. It has a hygienic structure.

Interconnection Fittings



32mm PP-RCT Spigot

Brass Spigot in 15mm, 22mm or 28mm

Wavin Interconnection Fitting: Direct connection from Wavin PP-R / PP-RCT to our flexible plumbing systems.

- ⊙ Optimise projects by combining larger dimensions in PP-R(CT) and smaller dimensions for bathroom and kitchen connections in a flexible pipe system (Hep2O or Tigris)
- ⊙ Simple plug-and-play connection
- ⊙ No need for threaded transition fittings
- ⊙ Lead-Free DZR brass for highest drinking water quality and future-fit installation
- ⊙ Quick and cost-effective solution



How it works

- ⊙ Double Spigot Fitting
- ⊙ 32mm PP-RCT Spigot can be used with any 32mm PP-R or PP-RCT Fitting Socket
- ⊙ Brass Spigot (3 sizes) can be used with any Hep2O Fitting Socket
- ⊙ Easy adaptation to Tigris using Hep2O-Tigris Coupler
- ⊙ Demountable if required

So many possibilities

- ⊙ Works with all larger sizes PP-R(CT) 40mm – 125mm via Reducing Tees or Weld-In Saddles
- ⊙ Works for systems using either PP-R or PP-RCT material. Available in grey or green.
- ⊙ Works with all sizes Hep2O 15mm-22mm-28mm
- ⊙ Works with all smaller sizes Tigris 16mm-20mm-25mm-32mm
- ⊙ All with only 3 Interconnection Fitting part numbers

Fittings



Dimension Combinations – all are possible without additional fittings

PP-R or PP-RCT	Hep2O 15mm	Hep2O 22mm	Hep2O 28mm	Tigris 16mm	Tigris 20mm	Tigris 25mm	Tigris 32mm
32mm PP-RCT Spigot	Any Fitting	Any Fitting	Any Fitting	15×16 Coupler	22×20 Coupler	22×25 or 28×25 Coupler	28×32 Coupler

Reducing Fittings to 32mm PP-RCT

	40mm	50mm	63mm	75mm	90mm	110mm	125mm
Reducing Tee	Y	Y	Y				
Weld-In Saddle			Y	Y	Y	Y	Y

The complete installation

Wavin is launching a new fitting that connects different drinking water pipe systems. The so-called Interconnection Fitting can connect PP-R or PP-RCT (fusion system) to Hep2O (push-fit polybutylene system). With another (already existing) fit-

ting, PP-R or PP-RCT can connect to the Tigris multilayer pipe as well. In that case the new Interconnection fitting is used in combination with the existing Hep2O – Tigris adapter.



Wavin Tigris

Acoustic Leak Alert

Wavin K5 and Wavin M5 are the first and only pipe fittings featuring the Acoustic Leak Alert function, a simple integrated system for detecting leaks during air pressure tests. This function enables the plumber to monitor the entire system and discover leaks caused by unpressed joints. The Acoustic Leak Alert feature makes it so that each unpressed pipe fitting will start making a loud whistling noise (80 dB), which makes finding the source of the leak very easy.

Using air instead of water during pressure testing prevents water from stagnating in the piping and effectively eliminates the risk of Legionella bacteria contaminating the water. In addition, testing using air prevents damage caused by freezing during winter and keeps the working environment cleaner, as no water ends up leaking into the workplace.



Acoustic Leak Alert

Save precious time in detecting leaks: simply listen for a whistling sound



Five Types of Press Jaws

No need to buy new equipment when switching to Wavin M5 pipe fittings



Up to 50 % Higher Interior Cross-Section

Optimised flow rate and maximum comfort for the end user



The Wavin Axial Press Fit system explained

Wavin Tigris MX is the most recent member of the Tigris-family. Being part of the Tigris family, Tigris MX perfectly matches the one-pipe-fits all proposition. With just one pipe, every fitting from the Tigris family can be applied, whether it is Push-Fit, Radial press or now also Axial Press. Even combinations of the various fitting systems can be installed with all products of the Wavin Tigris family without the use of transitions between each other.

Tigris MX offers an ultimate flow thanks to the straight bore which is one of the biggest bores on the market for Axial Press systems. Dead space is reduced to a minimum leading to an utmost hygiene for drinking water applications. But also, for heating applications the Ultimate-Flow concept shows advantages, such as the more efficient use of heat pumps due to the improved flow properties.

With an easy to expand pipe and sliding rings in a distinctive black carbon look made of PVDF that can be assembled from both sides, installing of an Axial Press system has never been easier. Moreover, calibrating and chamfering of the pipe is not necessary, which saves valuable time and eliminates installation mistakes.

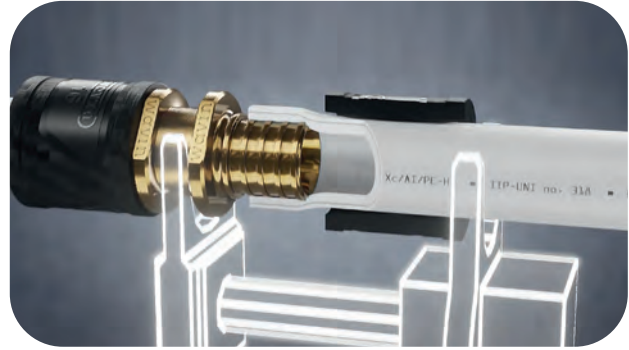

Ultimate-Flow Tigris MX connection.

Additionally, the leadfree DZR brass body is suitable for all markets around the globe. DZR material outstands and proves itself as a corrosion free material which is the perfect choice for installation systems. In terms of complying with guidelines, but also with sustainability, leadfree material enables a safe way of working in every way on a long term.

This makes Wavin Tigris MX the choice to work with when it comes to high performance in projects and a need for a failure-free, reliable, and durable connection.

Combined with the proven reliability of Tigris multilayer pipes, that have been successfully applied in many markets over decades, the Wavin Axial Press-system offers utmost reliability; it has even been tested beyond the high requirements for a 50-year lifetime simulation.

Finally, it fully profits from all benefits of the Tigris multilayer pipe; extreme big inner bore, the easy handling process, whether expanding, cutting, or bending! That is why the Wavin system warranty ensures a long and trouble-free lifetime.

Fitting design Wavin Tigris MX

Based on decades of knowledge and experience, Wavin Tigris MX combines and extends the existing Wavin Tigris unique features: An easy-to-handle, high flow performance pipe, that allows this new generation of fittings to go one step further in the optimization of efficient water supply and reduced flow resistance.

The ultimate flow concept by Wavin allows an up to one third reduced pressure loss¹. In addition to that, the one-fits-all technology allows users to combine several products of Wavin in one system. Wavin Tigris MX is available in the range of 16-32 mm.

ULTIMATE FLOW

Wavin Tigris K5/M5 already has set new standards for Radial press fitting with the optimized flow thanks to the increased inner bore.

Wavin Tigris MX raises the bar even further. Elaborating on the big inner bore of the Tigris pipe, the straight pipe - fitting bore of the Axial press concept offer optimized solutions in situations with highest requirements in terms of pressure loss. With the improved flow performance of the bigger inner bore, the use of Tigris MX even enables to explain why pipe dimensions can reduce the project costs.

As mentioned above, the ultimate flow connects further advantages when it comes to drinking water and heating applications – the absence of dead space comes along with an improvement of hygienic properties of the system.

No stagnating water eliminates the risks of potential legionella growth and ensures safety for every user. In terms of heating applications, less flow resistance ensures the efficient use of heat pumps. Build safe and sustainable environments with Wavin Tigris MX!

Tool-Fit

The story of easy to install of Wavin Tigris MX continues in the use of tools. Wavin offers a wide range of manual and battery tools for reliable and fast installation. But on top, also the commonly used tools on the market can be used for expanding and sliding.

Only the expander heads that are dedicated for the Wavin multilayer pipes are customized. In that way, no new equipment is needed and a switch to the new Wavin Tigris MX system can easily be done without high investments in new tools!

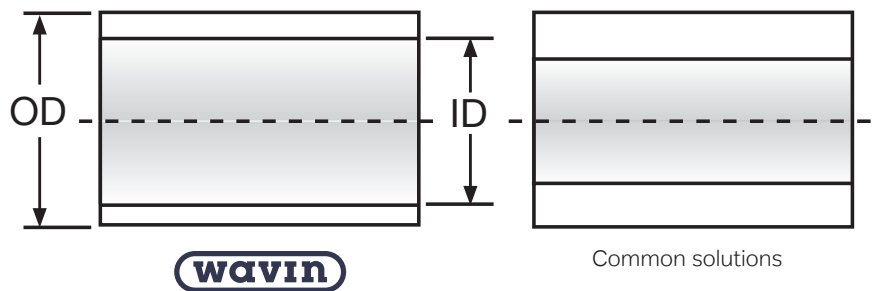

¹) In comparison to common solutions on the market.

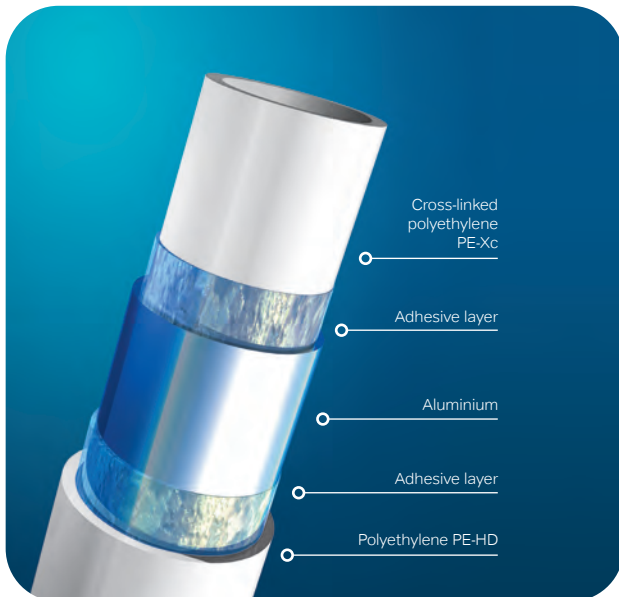

PE-Xc/Al/PE-HD Multi-Layer Pipes

The pipes consist of 3 layers: an interior layer consisting of cross-linked polyethylene (PE-Xc), a butt-welded aluminium jacket and an outer protective layer made of polyethylene (PE-HD). The cross-linked polyethylene of the interior layer guarantees the pipe lasting resistance to high temperatures and pressures.

Thanks to perfect bonding of the layers, PE-Xc/Al/PE-HD pipes boast properties that are typical for both plastics and metals. They are characterised, among other things, by high plasticity, which enables bending, while also maintaining stability of shape and high resistance to collapse. Thanks to the use of the aluminium layer, the pipes feature a 100 % reliable anti-diffusion barrier which prevents oxygen from entering the piping and thus protects the metal parts of the distribution system from corrosion. In addition, PE-Xc/Al/PE-HD pipes have very low thermal expansion, which greatly simplifies the planning and installation of the piping system.

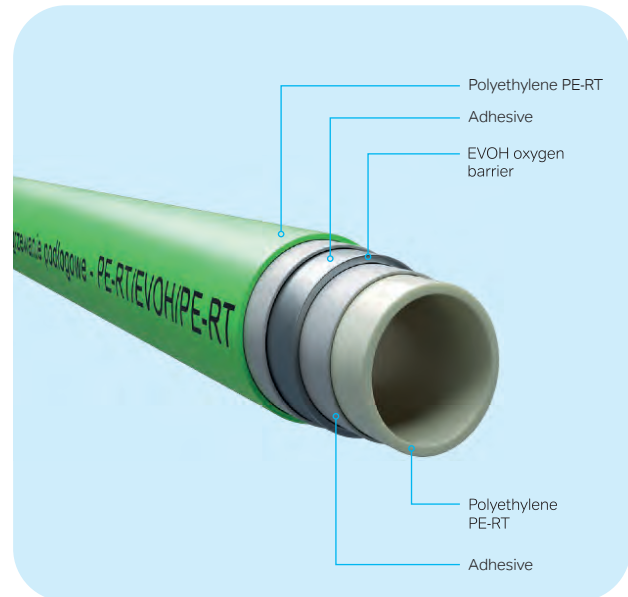

PE-RT/EVOH/PE-RT Multi-Layer Pipes

These multi-layer pipes consist of 3 layers: an interior layer made of polyethylene (PE-RT), a middle layer made of EVOH forming an oxygen barrier, and an exterior protective layer made of polyethylene (PE-RT).

These pipes are characterised, among other things, by high plasticity, which enables bending, while also maintaining stability of shape and high resistance to collapse. Thanks to the use of the EVOH layer, the pipes feature a 100 % reliable anti-diffusion barrier which prevents oxygen from entering the piping and thus protects the metal parts of the distribution system from corrosion.

The five-layered structure of the pipe ensures perfect protection of the EVOH layer from mechanical damage.

Since the pipes are coiled in long lengths (200 and 600 m for 16 mm diameter, and 200 and 560 m for 17 mm diameter), the amount of waste when laying loops is minimised.

Technical Parameters

Wavin Tigris K1



The Wavin Tigris K1 press-fit pipe fitting is made of high durability polyphenylsulfone plastic (PPSU).

Wavin Tigris M1



The Wavin Tigris M1 press-fit pipe fitting made of tin-plated brass is resistant to high temperatures corrosion and sedimentation.

Wavin Tigris K5



The Wavin Tigris K5 press-fit pipe fitting is made of high durability polyphenylsulfone plastic (PPSU).

Wavin Tigris M5



The Wavin Tigris M5 press-fit pipe fitting made of tin-plated brass is resistant to high temperatures corrosion and sedimentation.

Wavin Tigris MX



The Tigris MX axial-press fitting made of lead-free DZR brass and coupled with PVDF sliding ring provides ultimate flow rate and reliability.

	Wavin Tigris K1	Wavin Tigris M1	Wavin Tigris K5	Wavin Tigris M5	Wavin Tigris MX
MULTI JAW			✓	✓	
OPTI FLOW			✓	✓	✓
EASY FIT			✓	✓	✓
ACOUSTIC LEAK ALERT			✓	✓	
DEFINED LEAK	✓	✓	✓	✓	✓
IN 4SURE	✓	✓	✓	✓	✓
PIPE GRIP	✓	✓	✓	✓	
ULTRA SEAL			✓	✓	
Diameters	50–75 mm	50–75 mm	16–40 mm	14–40 mm	16–32 mm
Material	PPSU	Yellow brass	PPSU	Yellow brass	Brass
Pressing profile	U	U	U, Up, TH, H, B	U, Up, TH, H, B	Axial Press

Pipes in straight length

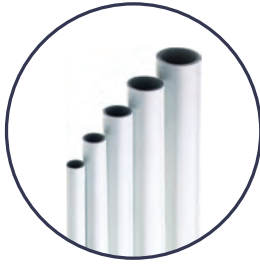

Three-layered pipes supplied in straight length, made of cross-linked polyethylene (PE-Xc), a butt-welded aluminium jacket and polyethylene (PE-HD).

Pipes in coil



Three-layered pipes supplied in coil, made of cross-linked polyethylene (PE-Xc), a butt-welded aluminium jacket and polyethylene (PE-HD).

Pipes in coil



Three-layered pipes supplied in coil, made of PE-RT, a butt-welded aluminium jacket and PE-RT.

Dimensions	16 – 75 mm	16 – 25 mm	16 – 17 mm
Operating conditions	95 °C / 10 bar maximum short-term temperature 100 °C	95 °C / 10 bar maximum short-term temperature 100 °C	90 °C / 10 bar
Material	Three-layered with aluminium foil PE-Xc / AL / PE-HD	Three-layered with aluminium foil PE-Xc / AL / PE-HD	Three-layered with aluminium foil PE-RT / EVOH/PE-RT
Use	Pressurised distribution of <ul style="list-style-type: none"> Ⓢ drinking water Ⓢ hot water Ⓢ central and underfloor heating Ⓢ compressed air and cooling 	Pressurised distribution of <ul style="list-style-type: none"> Ⓢ drinking water Ⓢ hot water Ⓢ central and underfloor heating Ⓢ compressed air and cooling 	Pressurised distribution of <ul style="list-style-type: none"> Ⓢ drinking water Ⓢ hot water Ⓢ central and underfloor heating Ⓢ compressed air and cooling
Main advantages	<ul style="list-style-type: none"> Ⓢ 10-year warranty on the whole system Ⓢ high temperature resistance to up to 95 °C (short-term up to 100 °C) Ⓢ quick and simple installation Ⓢ calculation programmes free of charge Ⓢ oxygen barrier 	<ul style="list-style-type: none"> Ⓢ 10-year warranty on the whole system Ⓢ high temperature resistance to up to 95 °C (short-term up to 100 °C) Ⓢ quick and simple installation Ⓢ calculation programmes free of charge Ⓢ oxygen barrier 	<ul style="list-style-type: none"> Ⓢ 10-year warranty on the whole system Ⓢ high temperature resistance to up to 90 °C Ⓢ quick and simple installation Ⓢ calculation programmes free of charge Ⓢ oxygen barrier

For details of how to optimise interconnection with Wavin PP-R or PP-RCT systems please see page 12.

Wavin Hep₂O



Hep₂O® is the professional polybutylene (PB) push-fit plumbing system for hot and cold water and central heating. It offers a fully comprehensive range of white fittings and unique features designed to reduce installation time and improve operating performance:

- Ⓞ In4Sure™ joint recognition
- Ⓞ Secure demounting with the new HepKey™ system
- Ⓞ New SmartSleeve™ for easy pipe insertion.

Range

The Hep₂O range comes with a wide variety of pipes, (demountable) fittings and manifolds in 10, 15, 22 and 28 mm (non-standard sizes on request). Hep2O pipes are available as Standard pipe removed barrier pipe (incorporating an oxygen barrier to inhibit oxygen permeation). All Hep2O fittings are designed to also connect directly to copper pipework.



Push-Fit plumbing system



Range

Category	Product
Pipes	Coils Conduit pipe Straight lengths Barrier pipe
Fittings¹⁾	Elbows Straight connectors Tap connectors Tees Spigot reducers Demountable stop end
Auxiliary fittings	Brass adaptors (available in DZR and non-DZR brass grades) Valves Tap connectors
Manifolds	2-Port 3-Port 4-Port Modular Multi-Port
Accessories	Hep ₂ O joint test kit Central heating & water services calculator Pipe support sleeves Cold forming bends Pipe clips and cutters

¹⁾ All fittings are pre-lubricated - no additional lubrication required

Applications

Hep₂O is suitable for most domestic and commercial plumbing applications: hot and cold water services and heating. In addition to new construction, the extreme flexibility of the Hep₂O pipe means it is the ideal solution for renovation, system extensions and situations where space is restricted. This means Hep₂O is widely used on mobile homes, portable homes and boats, as well as in traditional residential and commercial plumbing installations. The compatibility of Hep₂O fittings with copper ensures a simple, fast and reliable method of jointing to traditional materials on site. Hep₂O pipe

is also the ideal material for use in conduit 'pipe-in-pipe' installations where the combination of pipe flexibility and straight coil technology gives significant advantages for ease of handling compared to other pipe materials.

Quality requirements

Hep₂O carries a British Standard Kitemark against BS7291 parts 1 & 2 Class S. Hep₂O meets the requirements of EN15876 ISO 21003 and is certified by numerous European test laboratories including DVGW, KIWA and AENOR. The system also has approvals in many non-European markets including Australia, New Zealand, South Africa and China.

System benefits

- In4Sure joint recognition**
In4Sure tells you when the pipe is inserted. Just insert the pipe into the fitting then rotate it. If it's fully inserted you will feel a 'rumbling' sensation, caused by the profiled end of the pipe support sleeve making contact with the castellated seat inside the fitting.
- New SmartSleeve**
The clever design of the SmartSleeve pipe support sleeve reduces the force required to push the pipe into the fitting.
- New HepKey demounting system**
The new HepKey makes demounting quick, easy and tamper-proof, so joints only come apart when you want them to.
- Highly flexible, white PB pipe**
Easily cabled into position and fewer fittings required. With the straight coil technology the pipe stays straight when uncoiled.
- Compatible with copper pipe**
All fittings are compatible with copper pipe – ideal for renovation.
- Streamlined, white fitting**
The white colour combined with a slim, streamlined and altogether more stylish design, means Hep₂O fittings are well accepted for 'on view' or 'on show' applications.
- Colour coded packaging**
Packaging is colour coded for easy identification: 10 mm green, 15 mm blue, 22 mm red, 28 mm orange.

Key Features and Benefits

In4Sure – Feel the Rumble

- ① Tells you when the pipe is fully inserted
- ① Simply insert, twist and feel the rumble for a secure joint
- ① Unique feature which removes installer concerns regarding pipe insertion
- ① Excellent for connections in awkward places

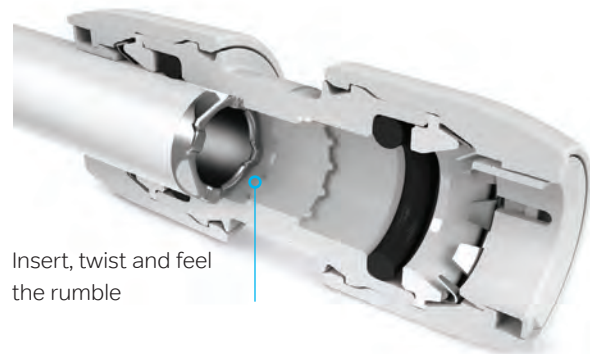

Insert, twist and feel the rumble

HepKey System

HepKey - Secure Demounting

- ① Joint is secure & tamper proof once pipe is inserted
- ① Cap cannot be removed so components are held captive
- ① If installer adjustments are needed pipe can be easily removed with HepKey or HepTool
- ① Pipe & fitting can then be reused
- ① No risk of accidental release



Hep₂O Flexible Pipe – one pipe for all applications

- ① Flexible pipe made from Polybutylene
- ① SmartPack acts as pipe dispenser
- ① Straight Coil Technology remains straight once uncoiled
- ① Competitors PEX pipe is difficult to work with will coil up like a spring unless retained

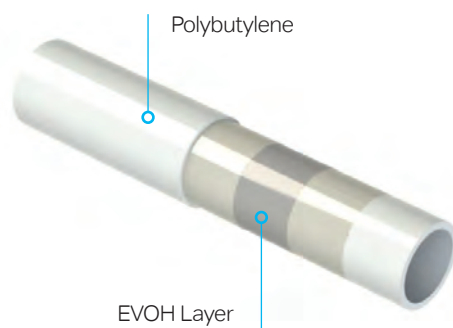

Full compatibility with Copper

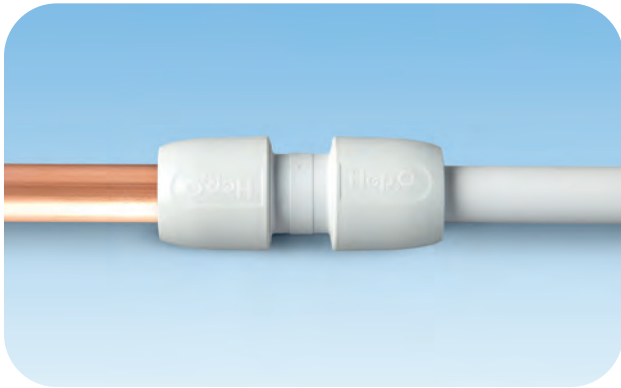

Example 1: Copper Pipe with Hep20 Fitting
(Including demounting & re-use)

Wide range of Fittings



Accessory Products

Flexible Tap Connectors

- ⊙ Wide range of SKU's
- ⊙ White and braided hose
- ⊙ Various sizes and lengths

Demountable Stop-End



Wavin Comfia Composite Manifold



The unique Wavin Composite Manifold is easy to install and gives you unrivalled flexibility.

Main Features

- ⊕ Lightweight: simple to assemble and easy to install
- ⊕ No special tools required
- ⊕ Can be assembled in either left or right configuration
 - Ports can be assembled facing up or down as required to supply rooms above or below the manifold location
- ⊕ Easily extendable: additional circuits can be added at any time
- ⊕ Unique 'Memory Ring' enables individual circuit isolation, with quick and simple balancing without tools
- ⊕ A single circuit can be isolated and balanced without unbalancing the system
- ⊕ BBA certified for a 25 year service life

Single Circuit Controls

A cost effective way to control a single room or smaller project is to use a single circuit control. This incorporates a standard circulator with an advanced mixer valve, to ensure the water flows at the correct temperature around the system. A single control is suitable for circuits smaller than 100m² with a heated floor area of 20m² or less. Simply use an adaptor and spigot elbow to connect the pipe circuit to the unit. For rooms of up to 24m² you can split the coil and use a tee fitting to create 2 circuits.

Manifold Design

1. Automatic Air Vent (AVV)
2. Flow Temperature Gauge
3. Flow Rate Indicator
4. Wall Mounting Bracket
5. Manual Head
6. Pipe Connectors 16–20mm
7. Combined Pressure and Temperature Gauge
8. Fill and Drain Valve
9. Connection for Isolating Valves

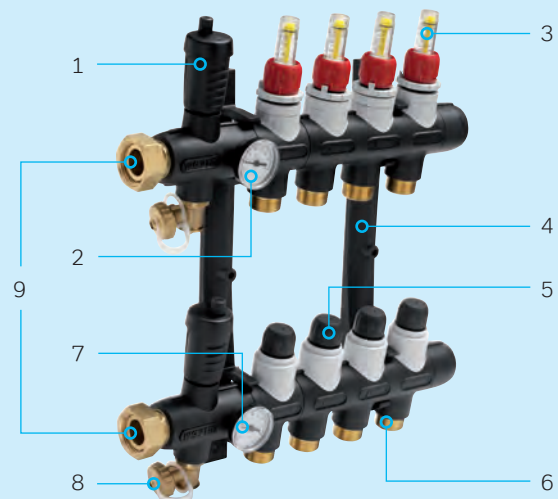

Stainless Steel Blending Manifold



The Stainless Steel Blending Manifolds are used for distributing and regulating the volume of flow in low temperature floor heating or cooling systems.

This Manifold blends and reduces the water temperature from the heat source to the correct operating temperature for the underfloor heating. The pump manifold utilises a Grundfos UPM3. The maximum permissible continuous operating pressure is 5 bar at 80°C. The maximum permissible test pressure is 10 bar at 20°C during the pressure test. The manifold is complete, for each circuit, with shut-off and control valves that can be motorized on the return and 0-6 lit/min flow rate gauges on the flow, both with 3/4" eurocone connections. Including fill/drain tap, manual air vent valves, and mounting brackets. The manifold is made of stainless steel, and for each circuit it is complete with control and shutoff valves that can be motorized on the return, and 0-6 lit/min flow rate gauges on the flow.

The manifold is complete with fill / drain taps, and manual air vent valves installed on the flow and the return, as well as mounting brackets.

The sealed actuator units also allow safe operation when ports are serving circuits above the manifold. The manifold has 1" flow and return primary connections which can be handed to

suit specific requirements. The manifold can be used to manage up to a maximum of 12 radiant circuits, and complete with:

- ⊙ 0-6 lit/min flow rate gauge
- ⊙ Shut-off valve that can be motorized, on the return
- ⊙ Fill and drain taps
- ⊙ Manual vent valves

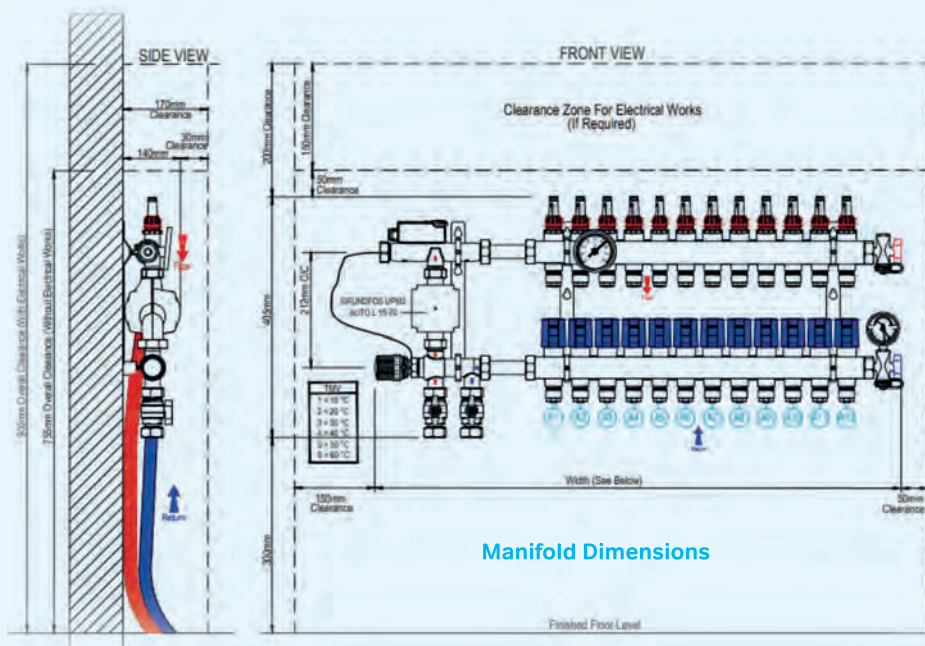

Wavin SiTech+



System description

Wavin SiTech+ is a mineral reinforced polypropylene (PP) soil and waste system. The system offers increased robustness, low-noise properties and improved ease of installation.

Its flexible connectivity and push-fit system makes SiTech+ a complete plug and play solution for waste water discharge in buildings.

Quality of living is an important consideration in building design. A reduction of noise in water discharge systems improves endexperience in both living and working environments. Wavin SiTech+ meets the latest construction requirements and fulfills customers' demand for increased comfort and quality.

Wavin SiTech+ meets system requirements for soil & waste discharge systems (EN 1451-1), including noise reduction and fire resistance (EN 13501-1). The emitted noise level of SiTech+ is measured by the Stuttgart Fraunhofer Physical Constructions Institute (DIN EN 14366).

Wavin SiTech+ is the ideal solution for installation in multi-storey building and those that are particularly sensitive to noise like apartment buildings, hotels, offices, hospitals, elderly homes and libraries.

Wavin SiTech+ can be used for water discharge at temperatures up to 90°C, with peaks of to 95°C for short periods. It can also be used at low temperatures up to -20°C. This durability makes it an ideal solution for extreme-temperature drainage areas such as kitchens, laundromats and industrial waste environments.



Key system benefits



Optimal noise performance

Wavin SiTech+ is an innovative soil and waste system with proven low noise technology. SiTech+ has an optimized 3-layer pipe structure for reduced noise levels. The fittings have an increased weight by 20% for improved acoustic comfort during water flow.



Easy to install

Better handling during installation due to the grip features. Ribbed fittings provide enhanced grip for easy installation in complex environments. SiTech+ is perfect for any project, from small renovations to large-scale construction jobs.



Angular rotation guidance

Angular rotation guidance to align and rotate fittings in the right direction. Fittings have different markings at 15° and 45° intervals for easy alignment. SiTech+ makes it easy to align fittings which need to be positioned at a rotated angle.

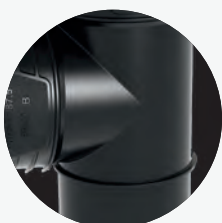

Insertion depth check

Insertion depth check on fittings to make a secure and safe connection. These easily visible SiTech+ markings can also confirm the exact 10 mm space needed to cope with thermal expansions at long pipe lengths.



New black color

The new black color adds to the durability and robustness of SiTech+. The black color improves protection against UV radiation when stored outside at a building site. Furthermore the matte black finish is less sensitive to dirt and gives the system a professional appearance.

Acoustics



- ⊙ Swept branches for minimal flow disturbance in the down pipe.
- ⊙ Due to unique system bracket and high structure born sound prevention.



Fig. 1: Double branch.



Fig. 2: Wavin System bracket.

In studies conducted at the Fraunhofer Institut für Bauphysik (Fraunhofer Institute for Building Physics), Stuttgart, Wavin SiTech+ has proven optimal sound absorption. The tests were performed in a laboratory accredited by the German Accreditation System for Testing (DAP, file no. PL-3743.26) according to standard EN ISO/IEC 17025.

The measurements in this test were performed following German standard DIN EN14366 and DIN 52219:1993-07; noise excitation by stationary water flow with 0.5 l/s, 1.0 l/s, 2.0 l/s., 3.0 l/s and 4.0 l/s.

Sound insulation by SiTech+

Wavin SiTech+ is an innovative soil and waste system with proven low noise technology. SiTech+ has an optimized 3-layer pipe structure for reduced noise levels. The fittings have an increased weight by 20% for improved acoustic comfort during water flow.

A contribution to sound protection is made by the special product design and system solutions.

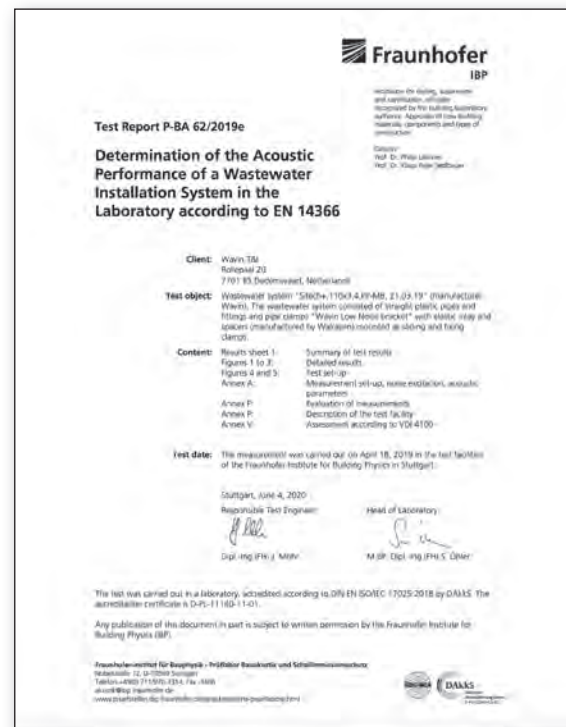

Noise calculation software

Determination of the sound level as conducted by Fraunhofer Institut Bauphysik is in general useful to determine the noise level of a pipe system in a static situation. The test method is, however, based on a laboratory set up in which all building parameters are kept the same except for a change in water flow. As a result it is impossible to obtain by this test a realistic figure of the noise levels for the protect chambers of actual projects.

Technical parameters

Range

Wavin SiTech+ offers a complete range of pipes and fittings in PP-MD, from 32 mm to 160 mm.

Diameter DN/OD	Thickness mm	Socket Length mm	Class
32	1,8-2,2	43	S16
40	1,8-2,2	45	S16
50	1,8-2,2	47	S16
75	2,6-3,1	53	S14
90	3,1-3,7	57	S14
110	3,4-4,0	64	S16
125	3,9-4,5	71	S16
160	4,9-5,6	76	S16

Technical Specifications

Pipe structure |

Co-extruded 3 layers pipe. PP mineral filled for more strength and durability, even resistant at low temperatures.

Connections |

Push-fit SBR rubber system, to obtain fast, safe and reliable installation.

Fire behavior |

Class C-s2, d0 according to EN13501-1.

Density | Pipe 1.15–1.3 gr/cm³; Fitting 1.4–1.6gr/cm³.

Working Temperature |

90°C continuous temperature; 95°C peak temperature.

Expansion coefficient ≈ 0,12 mm/m/K.

Impact Test -20°C according to EN744.

Ring Stiffness > = 5,5 Kn/m² (ref. OD110)

Conformity certification |

PIIP (n°1866 - 1867 - 1868)

DIBT (n° Z-42.1-539)

ITB (n° AT-15-7703).

Applications

Wavin SiTech+ is the ideal solution for both residential and non-residential buildings, where customer put more attention to low-noise properties (hotels, offices, hospitals). Thanks to the mineral filled, the system can be even be installed till -20°C air temperature.

Certifications

Wavin SiTech+ meets all standards set for soil & waste discharge systems (EN 1451-1), application EN12056-2, fire behavior EN13501, and noise protection according to the Italian Standard D.P.C.M. 05.12.1997. The low noise performance has been measured at the Fraunhofer Institute in Stuttgart, according to the EN 14366. Company meets quality requirements according to ISO 9001, and environmental requirements according to ISO 14001.

Technical features

- Outer layer made of black polypropylene polymer. Resistant to environmental influences.
- Middle layer made of polypropylene copolymer. With mineral fillers for good soundproofing properties
- Inner layer made of grey polypropylene copolymer. Particularly resistant to aggressive waste water. Smooth inner pipe surface for good sewage drainage. Chemically resistant. Inspection-friendly thanks to the light inner pipe surface.

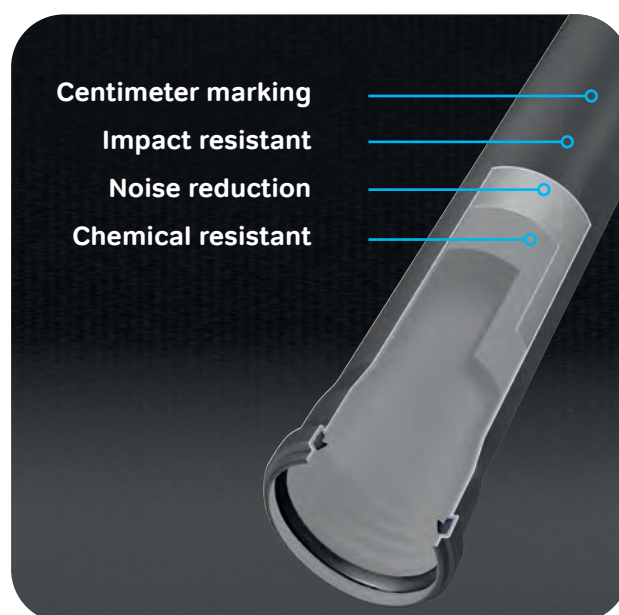

Wavin AS+



Advantages of the system

- ⊕ less noise
- ⊕ easier installation
- ⊕ easy determination of the rotation angle
- ⊕ insertion depth control
- ⊕ new blue seal

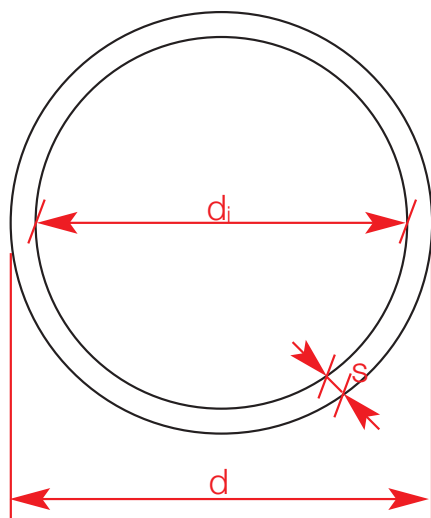

Characteristics of Wavin AS+

Material

Polypropylene, mineral reinforced.

Physical properties

Properties	Reference value
Density	1.90 g/cm ³
Temperature resistance	long-term resistance 90 °C Short-term resistance to 95 °C
Chemical resistance	pH 2 – 12
Thermal expansion	0.06 mm/m/K
E-Module	1800 N/mm ²
Flammability class	B2 DIN 4102-1

Color

Light gray RAL 7035

Pipe data

DN	d ¹⁾	d _i ²⁾	s ³⁾
50	50	44	3.0
75	75	68	3.5
90	90	80.8	4.6
110	110	99.4	5.3
125	125	114.4	5.3
160	160	148.8	5.6
200	200	188	6.0

¹⁾ Outer diameter in mm

²⁾ Internal diameter in mm

³⁾ Wall thickness in mm

Marking

Wavin AS+, nominal width, date, certification mark, material, fire class

Example: Wavin AS+, DN 110, date, Z.-42.1-569, mineral reinforced PP Ü DIN 4102, B2

Wavin AS+ has unique features that contribute to an easy and safe installation

- ⊕ new patented blue pre-lubricated seal will make it easier and speeds up assembly
- ⊕ shaped shaft of the fittings reduces compared to the Wavin AS push power by 50%
- ⊕ blue seal profile ensures 100% tight and secure installation
- ⊕ thanks to the unique composition of the material, it perfectly absorbs sound markings on the necks facilitate assembly and directional orientation fittings
- ⊕ checking the depth of insertion of the stem into the throat using a marker on the stem of the fittings
- ⊕ specially adapted necks allow a better grip and make it easier construction
- ⊕ compact design is perfectly adapted for small and narrow premises



Double branch



Wavin system sleeve

Acoustic properties

- ⊕ Rounded branches to minimize flow noise from the flowing media.
- ⊕ A special sound-absorbing sleeve system for minimization of noise transmission to the supporting structure

The tests were carried out in a laboratory accredited by the German accreditation system for testing (DAP, file no. PL-3743.26) according to EN ISO/IEC 17025.

The measurements in this test room were carried out according to the German standard DIN EN14366 and DIN 52 219:199307; noise excited by stationary by water flow with 0.5 l/s, 1.0 l/s, 2.0 l/s and 4.0 l/s.



Institution for testing, supervision and certification, officially recognized by the building supervisory authority. Approvals of new building materials, components and types of construction.
Director:
Prof. Dr. Philip Lenzner
Prof. Dr. Klaus Peter Sydler

Test Report P-BA 63/2019e

Determination of the Acoustic Performance of a Wastewater Installation System in the Laboratory according to EN 14366

Client: Wavin TSI
Rollepaal 20
7701 BS Dederswaart, Netherlands

Test object: Wastewater system "Wavin AS+, DN/DØ 110 x 5.3, 05.11.2018" (manufacturer: Wavin). The wastewater system consisted of straight plastic pipes and fittings and pipe clamps "Wavin Low Noise bracket" with elastic inlay and spacers (manufactured by Wavraen) mounted as sliding and fixing clamps.

Content: Results sheet 1: Summary of test results
Figures 1 to 3: Detailed results
Figures 4 and 5: Test set-up
Annex A: Measurement set-up, noise excitation, acoustic parameters
Annex F: Evaluation of measurements
Annex P: Description of the test facility
Annex V: Assessment according to VDI 4100

Test date: The measurement was carried out on April 17, 2019 in the test facilities of the Fraunhofer Institute for Building Physics in Stuttgart.

Stuttgart, May 14, 2019



Dipl.-Ing. (FH) J. Mohr

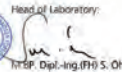

Dipl.-Ing. (FH) S. Ohler

The test was carried out in a laboratory, accredited according to DIN EN ISO/IEC 17025:2005 by DAkkS. The accreditation certificate is D-PL-11140-11-01.

Any publication of this document in part is subject to written permission by the Fraunhofer Institute for Building Physics (IBP).

Fraunhofer-Institut für Bauphysik - Prüflabor Bauakustik und Schallschwingungsschutz
Neckarstraße 12, D-70569 Stuttgart
Telefon +49(0) 71 4370-3314, Fax -3406
akustik@ibp.fraunhofer.de
www.fraunhofer.de/bauibp/derivate/qualifizierung.html



PVC-U Soil & Waste Systems



Soil & Waste system is a system which intended to discharge wastewater into larger drainage systems to the outside of the building. S&W product group is the largest product group in Wavin. There are more than 15 different systems produced in more than 10 production sites in different countries of the world. available.

PVC-U pipes for wastewater discharge systems are produced according to EN1329-1 standard. The pipes are suitable for both B(building) and BD (Building & Drainage) applications. The system can operate until 50-55°C in long term and 70-75°C in short term load.

Wide range of diameters are available starting from 32 to 315mm outer diameter. Also, the pipe length varies from 150mm to 6 meters.

Application Areas

PVC-U S&W Systems are used safely in many type of buildings such as hotels, residence, villa, hospital, school, industry etc

- ⊙ Wastewater discharge
- ⊙ Ventilation systems
- ⊙ Electrical and communication infra systems
- ⊙ Rainwater discharge
- ⊙ Industrial areas



Connection Methods

Unplasticized polyvinyl chloride (U-PVC) is one of the most common S&W system's basic material. The products can be in different colors. The systems can divide into two groups according to the jointing methods.

Push-fit systems are effortless, quick and reliable. You may find some of the main PVC-U S&W systems in the following.

Push-Fit Connection



Solvent Weld (Glue connection)



Wavin PVC/PP HT

*This below small table can be used for the consistency of other systems.

The system description Wavin PVC/PP HT System

Material	PP for 32 and 40mm PVC-U for 50,75 and 110mm
Diameters (OD)mm	32,40, 50, 75, 110
Colour	Grey / White*
Connection Method	Push-fit connection
Production Location	Poland

*White – dia 32, 40 mm

Wadal PVC

The system description Wadal PVC System

Material	PVC-U
Diameters (OD)mm	Available in 32mm up to 160mm
Colour	Grey
Connection Method	Solvent Weld (Glue connection)
Production Location	Netherland

Wavin Pilsa PVC

The system description Wavin Pilsa PVC

Material	PVC-U
Diameters (OD)mm	Available in 50mm up to 315mm
Colour	Light Grey
Connection Method	Push-fit Connection
Production Location	Turkey

System benefits

- ⊕ PVC-U Pipes and fittings offer long lasting and leak proof systems in the building. Systems are fully compatible with outside of the building sewage systems.
- ⊕ Complete plastic
- ⊕ High chemical and corrosion resistance
- ⊕ Lightweight
- ⊕ Easy to Install
- ⊕ Reliable and durable, whether using the easy rubber ring push fit system or solvent cement, the system is highly durable with high tensile and high impact resistance.
- ⊕ Smooth interior prevents growth of deposits and assuring low friction loss and high flow rates.
- ⊕ Fire resistance: PVC-U pipes are normally low flammable systems according to the EN13501-1 European Standard. This feature makes PVC-U system a perfect choice for high risers which needs to be comply "Building Fire Regulations".
- ⊕ Cost effective
- ⊕ Maintenance free
- ⊕ PVC-U has very low temperature expansion coefficient, much lower than PP

Hep_vO – Self-sealing waterless trap



Hep_vO – The waterless trap that won't leave you high and dry. The world's best selling waterless trap.

Hep_vO actively eliminates negative pressure within the waste system by opening and allowing in fresh air until a state of equilibrium with atmosphere is reached. It subsequently closes to reseal the waste system and prevent foul air release. This means that the venting of the waste system in high-rise buildings, or the inclusion of an air admittance valve in the waste system, is no longer necessary.

Can be used in place of a p-trap on all bathroom and kitchen fixture drains as well as HVAC condensate drains. Ideal for low or seasonal water flow applications where p-traps are prone to failure.

The perfect drainage solution for high-rise properties

Hep_vO is a unique self-sealing waste valve that prevents the escape of foul sewer air from waste discharge systems, and actively maintains the pressure equilibrium in soil and waste installations, which makes it perfect for high-rise buildings. As a dry sealing valve, Hep_vO utilises a purpose designed membrane to create an airtight seal between the living space and the drainage system. The self-sealing valve opens under the water pressure of an appliance emptying, and closes to form a tight seal after the appliance has discharged under normal atmospheric conditions.

For over 25 years, Hep_vO has successfully offered considerable benefits for the system designer. In addition, the Hep_vO hygienic self-sealing waste valve offers a number of benefits for professional installers and end users.



The hygienic alternative to a p-trap

- ⊕ The Hep_vO valve results in enhanced plumbing design and system efficiency
- ⊕ Unlike water seal traps, Hep_vO is not affected by siphonage and will therefore not allow the escape of foul air into the living space from drain or sewer
- ⊕ Hep_vO allows discharge water to pass easily through, regardless of the volume
- ⊕ Hep_vO allows the placement of a greater number of appliances together on fewer discharge pipes without compromising the performance of the sanitary discharge system
- ⊕ Hep_vO operates silently and is not subject to “gurgling” noises typically associated with siphonage and indicative of a breach in the water seal barrier
- ⊕ Independent tests confirm that Hep_vO performs silently when subjected to a range of abnormal pressures

Silent operation, no gurgling.

Elastomeric membrane prevents foul sewer air from entering the building.

Connects to 1¼" and 1½" BSP thread.

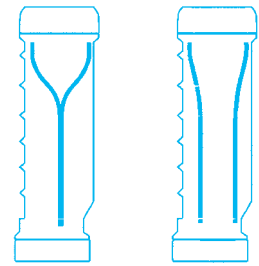
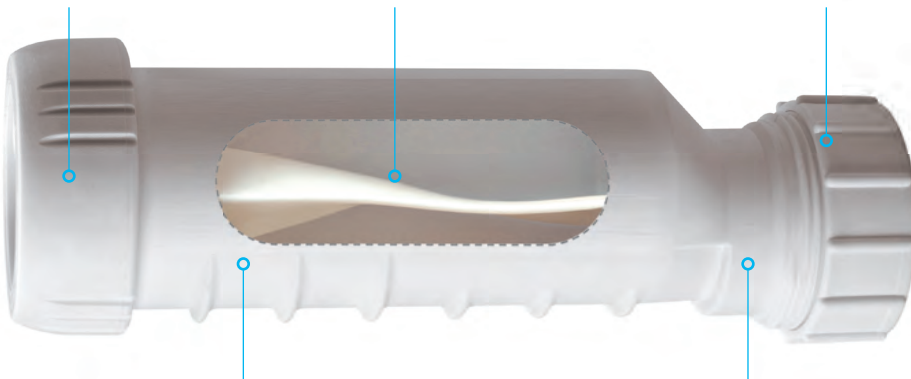

Not in use

Water flowing



ATS 5200-047:2005

Ideal for installation in confined areas and can be installed either horizontally or vertically.

Smooth bore prevents blockages and risk of stagnating solids.



Hep_vO can be installed either vertically or horizontally.



Hep_vO is ideal for installation in confined areas.



Hep_vO can be installed horizontally by using the 90° adaptor.

Hep_vO provides permanent protection from foul, unhealthy sewer gas which can carry viral pathogens into the living space.

The primary purpose of a trap is to protect public health by blocking noxious sewer gas from the living space of buildings. When a p-trap loses its water seal that protection is also lost. At best this leads to unpleasant odour and increased maintenance. At worst it can be a threat to human health.

The Hep_vO valve promotes hygiene, particular where an appliance is infrequently used. Hep_vO differs from conventional water traps, which could dry out or hold stagnant water, causing the emission of foul smells and enhance bacterial growth. Hep_vO has been extensively tested and is resistant to common chemicals such as cleaners and detergents containing sodium hydroxide and solvents.

For branch pipe ventilation

Hep_vO can act as an air admittance valve, allowing air into the drainage system when negative pressure occurs. Once equilibrium is reached the valve closes. Using the valve as an air admittance tool provides cost savings, as it eliminates the need for a traditional open vent pipe or an air admittance valve to be positioned on the stack in certain circumstances; simplifies system design, providing space and time saving benefits.

The use of Hep_vO, as it provides ventilation, can give more flexibility in pipe sizing, allowing the pipe run to be extended to 3m without needing to increase pipe size from 32mm.

For non-domestic situations, the use of multiple Hep_vO valves allows for simpler systems with less pipework & straight runs.

On completion of the installation, there is no need to perform self-siphonage and induced siphonage tests for branch discharge pipes from waste appliances.

Water held in conventional traps can become stagnant (Residues in the water trap can be fermented and produce odours and unhealthy air)

Suspended matter in water eg. soap scum/grease/saliva/etc.

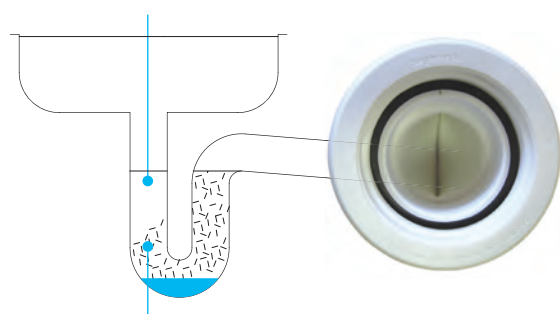

Solid matter eg. decomposing food particles/hair strands/skin flakes/nail clippings etc.

Operation of Hep_vO

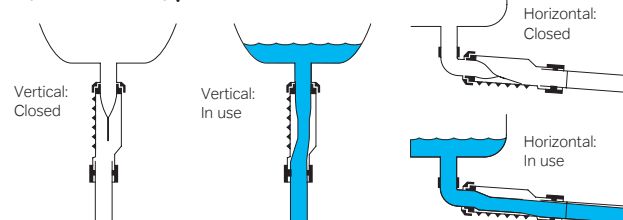

Schematic view for three basins

Using 32mm Hep_vO waste valve

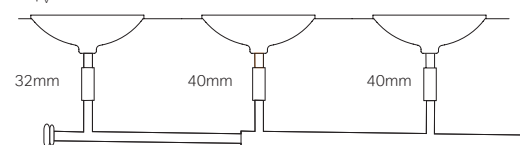

Using 32mm water seal 'P' traps

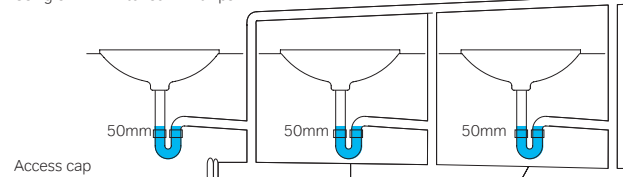

Technical parameters

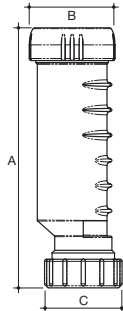

Hep_vO Hygienic Self-Sealing Waste Valve – DN metric pipe

Nominal Size mm	Part Number	Colour Option	Dimensions A mm	Dimensions B mm	Dimensions C mm
32*	BV1/M1	white	188	61	55
40*	CV1/M1	white	188	68	62

* Material: Polypropylene. For UK size waste pipes use part numbers BV1 (32mm) and CV1 (40mm)

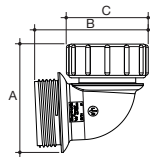

Hep_vO 87.5° Knuckle Adaptor – For Horizontal applications

Nominal Size mm	Part Number	Colour Option	Dimensions A mm	Dimensions B mm	Dimensions C mm
32*	BV11	white	66	70	50
40*	CV11	white	70	74	56

* Material: Polypropylene.

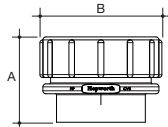

Hep_vO Running Adaptor – For installing Hep_vO in a pipe run – DN metric pipe

Nominal Size mm	Part Number	Colour Option	Dimensions A mm	Dimensions B mm
32*	BV3/M	white	43	55
40*	CV3/M	white	43	62

* Material: Polypropylene. For UK size waste pipes use part numbers BV3 (32mm) and CV3 (40mm)

Wavin QuickStream PE System

The Wavin QuickStream PE system is designed for negative pressure drainage of flat roofs. These are primarily the roofs of supermarkets, production and storage halls, sports arenas and stadiums, commercial and administrative buildings and other structures with roofs covering hundreds to thousands of square meters. HDPE pipes and pipe fittings are complemented by special plastic or metal roof drains, including accessories for various types of roof structure. Last but not least, the system includes a specially developed pipe mounting system. The advantage of the system is its high capacity while requiring less material compared to traditional gravity drain systems. There is, however, higher demand on the hydraulic design, precision and manufacturing quality of the system. The advantage of the system is its high capacity while requiring less material compared to traditional gravity drain systems. There is, however, higher demand on the hydraulic design, precision and manufacturing quality of the system.

Waste line piping is often subject to very high demands. It must withstand mechanical load, low and high temperatures, oils and petroleum products, as well as aggressive chemicals and solvents. The HDPE system is able to meet these demands for its entire lifespan.

Tightness

HDPE pipes and fittings are joined together through welding, which ensures high reliability and tightness of the joints. Even if the piping gets clogged or filled to full capacity, there is no danger of the joints coming loose and the pipes leaking. As a result, it is rightfully considered the safest and most reliable system in its class.

Durability and Flexibility

The system is resistant to impact even at low temperatures down to -40°C . It is extremely difficult to damage at normal temperatures. At the same time, the material is very flexible, resistant to high pressure and thermal shocks. It can be used even in places where thermal expansion, vibrations or sinking of the subsoil are a possible risk.

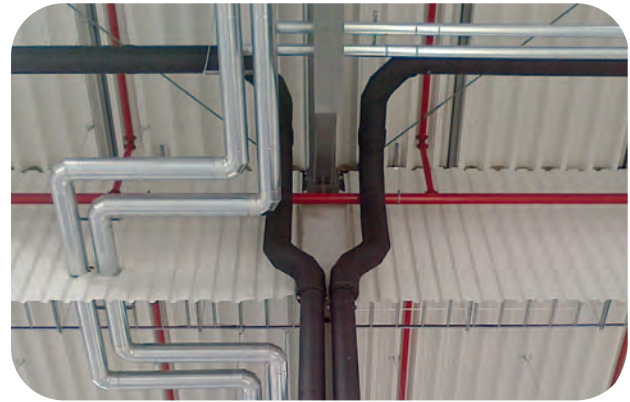

Resistant to Low and High Temperatures

HDPE can withstand high temperatures, in the short term to up to 100°C , and in the long term to up to 80°C . The piping is also resistant to low temperatures, down to approximately -40°C .

Resistance to UV Radiation

The system contains an approximately 2 % admixture of carbon black to ensure sufficient resistance to UV radiation.

Chemical Resistance

The Wavin HDPE system is highly resistant to chemicals and all organic and inorganic solvents. This makes it suitable for use in industry or laboratories.

Fun Fact

Several countries in Europe specifically require that internal rainwater drainage be made of welded HDPE. These include Germany or Italy.



Applications of Welded HDPE Indoor Waste Line Drainage

This permanently assembled, perfectly enclosed, leak-tight yet highly flexible system offers a wide range of uses not just in various branches of the construction industry, but industry in general. HDPE pipes and fittings can be used anywhere from sewer connection, to waste collection and drainage, to connections for plumbing fixtures.

Industrial and Logistical Buildings

In these structures, the system is used to drain flat roofs, usually in the form of negative pressure drainage. Nowadays, one would be hard-pressed to find a building of this type that does not use this kind of system.



Administrative Centres and Blocks of Flats

Commonly used for internal rainwater drainage and waste lines. In taller buildings, the system guarantees complete leak-tightness and joint permanence both in the event of sudden hydraulic surges and in internal overpressure in the system.



Industrial Application, Laboratories, Hospitals

Thanks to its high durability, flexibility and chemical resistance, the system is commonly used for technological waste line drainage in the chemical, food and pharmaceutical industries. It is also used in hospitals and laboratories.



Bridge Construction

Proper drainage of rainwater from bridge structures is a key prerequisite for safe traffic and protection of human life. The material is also used for these applications, primarily thanks to its resistance to UV radiation, its flexibility and ability to withstand low temperatures.



Technical Parameters

Wavin QuickStream PE Piping



The piping is made of HDPE and joined together through welding. The pipes can be either butt welded or resistance welded using welding fittings. A fully welded waste line system is primarily characterised by its leak-tightness. In the long-term, there is no tighter and more reliable waste line piping design.

Wavin QuickStream PE Pipe Fittings



The range of HDPE pipe fittings is vast and includes welding fittings as well. Aside from standard elbows, splitters and reducers, we also offer more atypical connection, transition and expansion fittings. In addition to welding, the system offers several other types of connection, such as socket joints, flanged joints or threaded joints.

Material Colour Product line Quality certificate Main advantages Application	HDPE polyethylene	HDPE polyethylene
	black	black
	d40-d315	d40-d315
	certification in line with EN standards	certification in line with EN standards
	<ul style="list-style-type: none"> ⌚ 100 % leak-tightness for the entire product life ⌚ resistance to negative pressure and internal overpressure ⌚ resistance to hydraulic surges 	<ul style="list-style-type: none"> ⌚ 100 % leak-tightness for the entire product life ⌚ widest selection of products, including various types of adapters ⌚ welding fittings without a bar code
<ul style="list-style-type: none"> ⌚ gravity and negative pressure rainwater piping, waste line piping, industrial waste line piping 	<ul style="list-style-type: none"> ⌚ gravity and negative pressure rainwater piping, waste line piping, industrial waste line piping 	

Wavin QuickStream PE Roof Drains



Negative pressure roof drains are produced in two versions: metal or plastic. Wide selection of accessories makes the roof drains suitable for almost any roof, regardless of its structure. Safety roof drains are also available.

Wavin QuickStream PE Mounting System



Specially developed mounting system designed for Wavin QuickStream PE piping. Effectively addresses thermal expansion of the piping and is optimised to make installation as quick as possible while using as few connecting fittings and components as possible.

Material	Polyethylene, PAGF, stainless steel, aluminium-silicon alloys	galvanised steel
	black, silver	silver
Product line	d40-d75	d40-d315
Quality certificate	certification in line with EN standards	certification in line with EN standards
Main advantages	<ul style="list-style-type: none"> ⌚ available in both plastic and metal ⌚ wide selection of accessories ⌚ quick and simple installation 	<ul style="list-style-type: none"> ⌚ amount of connecting fittings and components reduced to minimum ⌚ simple solution for fixed points ⌚ quick and simple installation
Application	⌚ negative pressure flat roof drainage	⌚ gravity and negative pressure rainwater piping, waste line piping

Wavin Kanion

The Kanion gutter system represents over 20 years of tradition and experience, which certainly translates into the quality and durability of the gutters. The elaborate shape and individual components, as well as the manufacturing technology, make Kanion a reliable and proven solution.

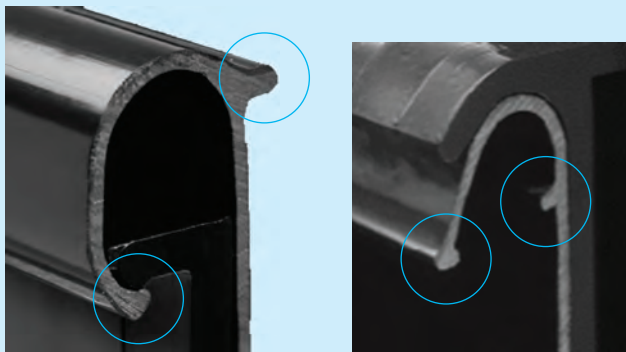

Outer layer
ensures colour durability
and gloss - aesthetic qualities.

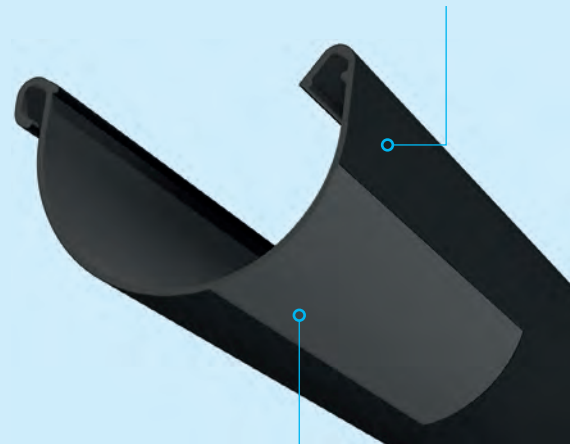

Inner layer
ensures strength,
impact resistance,
stiffness.

Advantages of the Kanion system

- ① Resistant to discolouration and variable atmosphere factors.
- ① Resistant to mechanical and chemical corrosion.
- ① Maintains high stiffness during use.
- ① It has leakproof joints.
- ① It has a high hydraulic capacity.

Refined shape

The external and internal curvature of the gutter is no accident. They give the profile a 4-point reinforcement. The 4 tabs/noses running the entire length of the gutter significantly stiffen it and cause it to stay vertical and horizontal and prevent it from deforming under the weight of snow or ice. The internal projection also prevents water from splashing onto the façade.

Watertightness of the Kanion system

The Kanion gutter system guarantees the highest level of watertightness through the use of unique solutions such as:

- ① Double lip seal for a double contact area and thus double protection.
- ① A gutter joint with an insert, which protects the gutter connection and the seal against dust carried by water, which may cause leakage.
- ① Fittings with double band, which secures the connection of the individual elements on the downpipe.

Technical data

Dimensions and colours

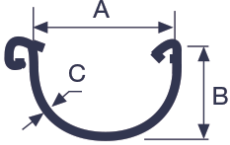
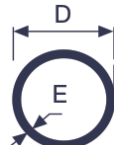
Gutter	Downpipe	Rainwater system	A	B	C	D	E
		Kanion 70	75	55	1,6	50	1,4
		Kanion 100	100	65	1,6	75	1,8
		Kanion 130	130	88	1,6	90	2,0
			130	88	1,6	110	2,2
		Kanion 160	160	117	1,6	110	2,2

Gutter Flow Capacity

Effective roof area (in square metres) can be calculated using the following formula:

Effective roof area = $(B + C/2) \times \text{roof length}$:



B – horizontal distance from the eaves to the roof ridge, C – height of roof

Maximum roof area to be drained by one outlet:

⊙ gutter fall 3‰ (3 mm per 1 m of the gutter)

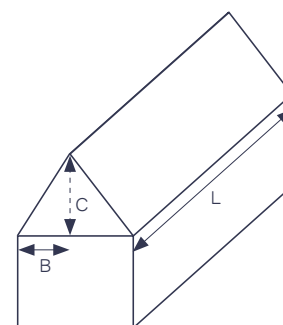
⊙ rainfall intensity 75 mm/h

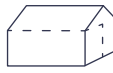

Maximum roof area (m ²)		Gutter 75* Downpipe 50*	Gutter 100* Downpipe 75*	Gutter 130* Downpipe 90*	Gutter 130* Downpipe 110*	Gutter 160* Downpipe 110*
Gutter length		2, 3 and 4 m				
Downpipe length		2 and 3 m	2, 3 and 4 m			
	Running outlet (end)	36	66	123	140	189
	Running outlet (centre)	72	132	246	280	378
	Angle – more than 2 m from the running outlet	Roof area lessen by 5%				
	Angle – within 2 m from the running outlet	Roof area lessen by 10%				

* in millimetres (mm)

Storage and transport

Pipes and gutters must be stored on a smooth surface, free of any sharp edges and surface roughness. Products must not be stacked in more than 7 layers, to ensure that elements stored at the bottom are not deformed. Fittings of various types must be stored indoors in their original packaging (foil bags) until un-packed. It is recommended that products are securely fastened while in transport. Loading and unloading of loose gutters and pipes must be manual. Special care must be taken when transporting products during winter, as low temperatures reduce the resistance of plastics to mechanical impact.

Standards and approvals

- ⊙ European Standard PN-EN 607
- ⊙ European Standard PN-EN 12200
- ⊙ European Standard PN-EN 1462
- ⊙ Approval of the National Institute of Hygiene no. HB/B/2830/01/98
- ⊙ Certificate of conformity KOT-ITB

The on-screen advantages of BIM by Wavin

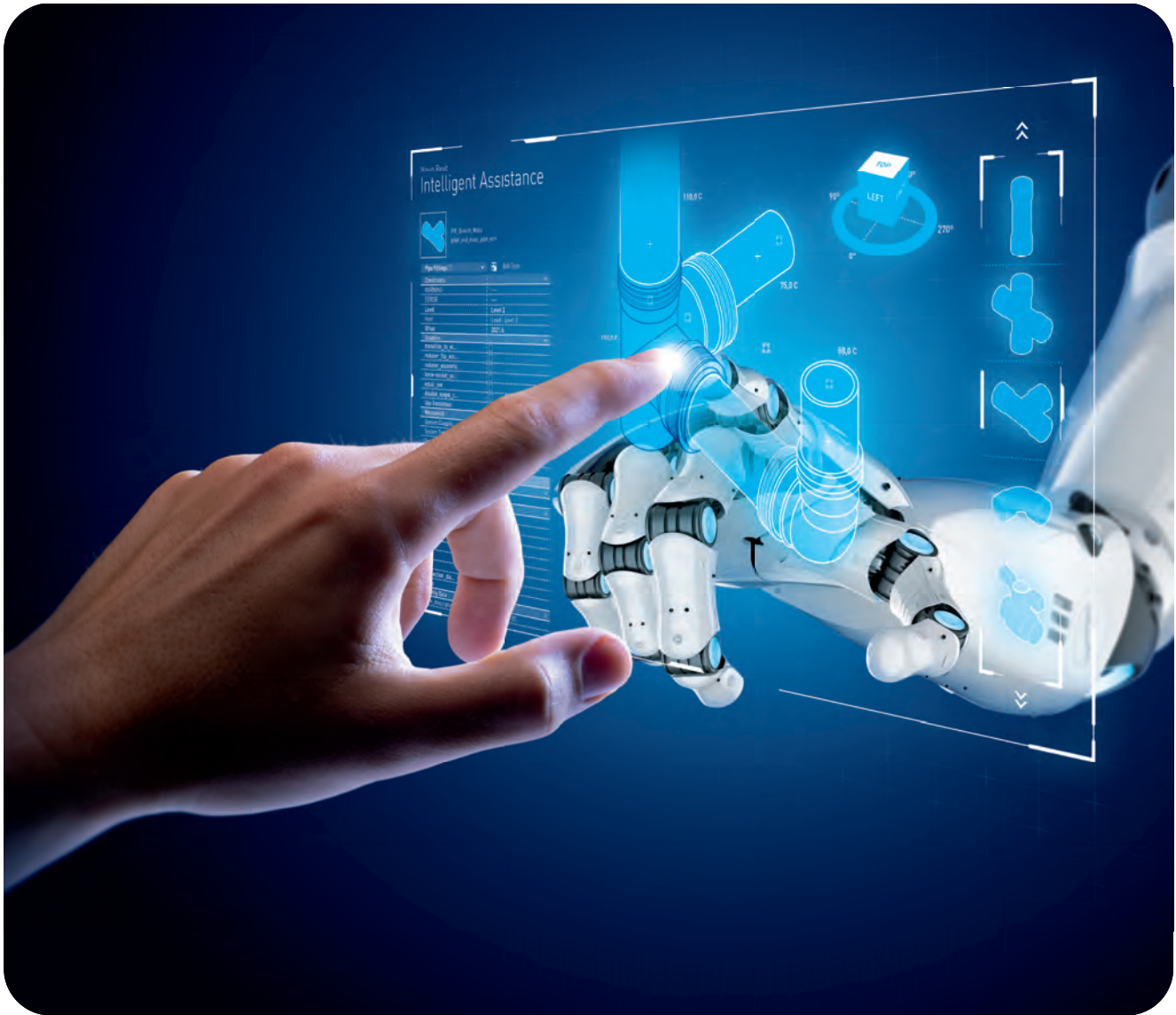

Pipe system designers finally have the BIM solution they've been waiting for. Our unique intelligent assistance, combined with 100% accurate product models, creates a powerful design tool that is detailed, accurate, easier, faster and more rewarding to use.

100% accurate content



Wavin's BIM is the only BSI kitemarked drainage package in the UK – a testament to its comprehensive qualities and detailed accuracy.

Our Revit Families support working with DN as well as OD pipe sizes, cover our full above ground product range and offer socketed pipe options not just plain-end pipes.

100% accurate content at LOD400 and accurate clash detection are the drivers of a wholly accurate representation of all the products in the 3D model.

The result is that, with Wavin, as designed is as built – so you can visualise exactly how the system will be installed.

Faster by design



Wavin BIM's intelligent assistance also enhances the efficiency of design departments. Significantly faster to use than competitor packages, it means precise models can be created in a fraction of the time and fed into the project earlier.

We have conducted side-by-side comparisons with a range of competitor packages to prove its superior performance.

Intelligent assistance



Given the complexity of pipe systems, restricted void space and the range of junctions, reducers, tees and pipe lengths, inserting a pipe system into a BIM model can be difficult and time consuming. By automating key aspects of pipe system design, the intelligent assistance within our packages not only speeds the process, it removes the risk of costly errors being made.

Ours is the only BIM content to feature a visual accuracy check. The system has automatic routing preferences and pre-configured bends, branches and reducers are inserted automatically as pipes are brought together. Accurate clash detection is a real money saver too, avoiding mistakes on-site being realised.

Automated Bill of Materials

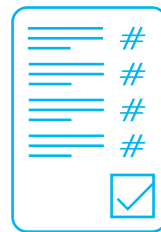

As each model is created, a Bill of Materials is automatically being built in the background to mirror it, detailing every product part and code you'll need to build it.

One click and the Bill of Materials can be extracted for precise ordering with virtually no waste.

Familiarize yourself with our wide assortment at www.wavin.com

- Water management
- Heating and cooling
- Water and gas distribution
- Waste water drainage
- Cable ducting



wavin

orbia 

Wavin is part of Orbia, a community of companies working together to tackle some of the world's most complex challenges.

We are bound by a common purpose:
To Advance Life Around the World.

Wavin Middle East | Tiffany Tower No. 2408W Cluster JLT Dubai / United Arab Emirates
Tel: +97 14 276 6968 | wavin.me@wavin.com | <https://wavin.com/en-ae>



Wavin operates a programme of continuous product development, and therefore reserves the right to modify or amend the specification of their products without notice. All information in this publication is given in good faith, and believed to be correct at the time of going to press. However, no responsibility can be accepted for any errors, omissions or incorrect assumptions.

© 2023 Wavin Wavin reserves the right to make alterations without prior notice. Due to continuous product development, changes in technical specifications may change. Installation must comply with the installation instructions.