

WAVIN TIGRIS K1
Press-fit system

Press-fit system for metal plastic pipes



Wavin Tigris K1 is the complete press-fit system for metal plastic (multilayer) pipes. The system can be used for sanitary (including potable water) and heating applications. Tigris K1 are blue press fittings with a fixed stainless steel sleeve. The press fitting is made of PPSU (polyphenylene sulphone) and guarantees corrosion resistance for the entire pipe system including the connections.

The Defined Leak Function (DLF) brings extra safety where it identifies unpressed fittings during the pressure test.

Wavin Tigris K1 offers a complete range in the dimensions 16, 20, 25, 32, 40, 50 and 63 mm. An extensive range of fittings, accessories and tools completes this hot and cold system. Wavin Tigris K1 can also be combined with the Tigris M1 and smartFIX system.

wavin

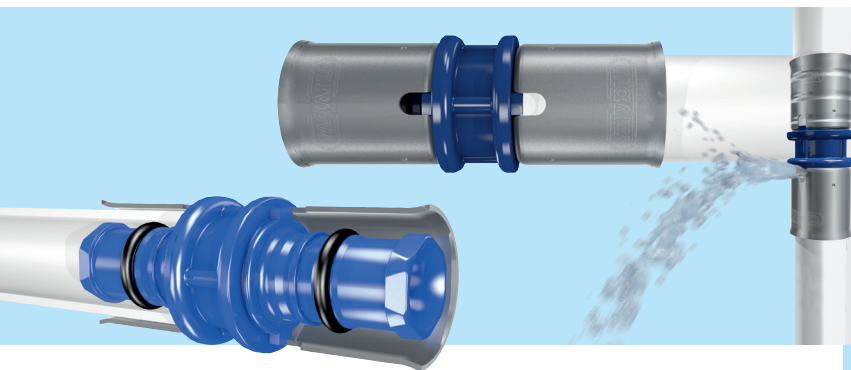

Quality requirements

Wavin Tigris K1 meets all requirements in accordance with ISO 21003 (class 2 and 5) standards. The system has been tested and approved by the DVGW (DVGW DW – 8501AU2286) and carries a wide set of national approvals as well.

Product specifications

Raw material pipe

5-layer composite pipe with oxygen-diffusion barrier. Inner layer made of crosslinked polyethylene (PE-X); middle layer of aluminium and outer layer of PE.

Raw material fittings

Fitting body made of polyphenylene sulphone (PPSU), fixed stainless steel pressing sleeve. Transition fittings are made from De-Zincification Resistant Brass.

Wall thickness pipe (mm)

DN	Wall thickness	DN	Wall thickness
16	2.0	40	4.0
20	2.25	50	4.5
25	2.5	63	6.0
32	3.0		

Hot water resistance 100° C short term loading,
95° C long term loading
(max. 6 bar).

Max. permanent operating 10 bar (at Tmax = 70° C)

Thermal expansion coefficient (pipe)

0.025 – 0.030 mm/mK

Thermal conduction (pipe) 0.4 W/mK

Pipe roughness 0,007mm

Applications

The Wavin Tigris K1 system is suitable for hot and cold water applications as well as radiator heating systems in residential, public and industrial buildings. Because of a wide range of fittings with clever solutions for special problems, the systems are optimally suited not only for new buildings but also for renovation of older systems.

System benefits

- ⦿ **Defined Leak Functionality (DLF)**
Fitting will leak if not pressed
- ⦿ **Reduced push-in force**
Patented sculptured (hexagonal) nose reduces push-in force significantly
- ⦿ **Pipe retention of 2 meters**
The sculptured (hexagonal) fitting nose improves pipe retention. An unpressed fitting will retain a 2 meter length of vertical pipe with no risk of it falling out. The installer can locate and bring the pressing tool without needing to hold the pipe in place.
- ⦿ **Free of encrustation, corrosion resistance**
Outstanding resistance to corrosion and encrustation from aggressive water supplies.

Other features

- ⦿ Quick, easy and safe assembly by proven press technique
- ⦿ Minimised linear expansion
- ⦿ Visual connection check through observation window in the sleeve
- ⦿ Visual check whether fitting is pressed or not
- ⦿ 3-in-1 concept: 1 metal plastic pipe for 3 fittings (Tigris M1, Tigris K1, smartFIX)
- ⦿ Compatibility with universal press tools
- ⦿ Special threaded transition fittings

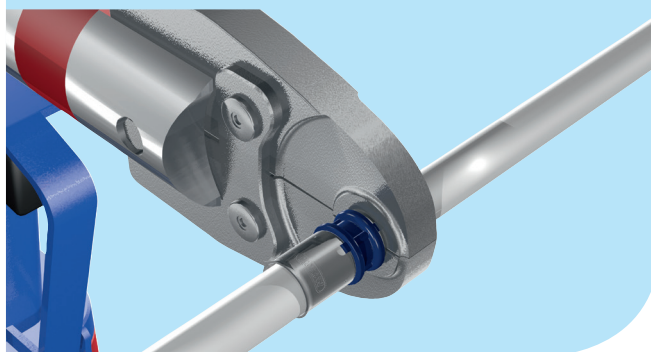

Wavin is part of Orbia, a community of companies working together to tackle some of the world's most complex challenges. We are bound by a common purpose: To Advance Life Around the World.

- ⦿ www.wavin.ae for Middle East & North Africa
- ⦿ www.wavin.asia for Asia Pacific

© 2020 Wavin Wavin reserves the right to make alterations without prior notice. Due to continuous product development, changes in technical specifications may change. Installation must comply with the installation instructions.

