

Wavin Q-Bic Plus Low Carbon

Product description

Wavin Q-Bic Plus LC is a geocellular unit for attenuation and infiltration tanks of rainwater. Made from polypropylene that is 100% circular, the system offers excellent and consistent material properties, ensuring a long lifespan. The optimal and sustainable solution for fastest installation and total access for inspection and cleaning.

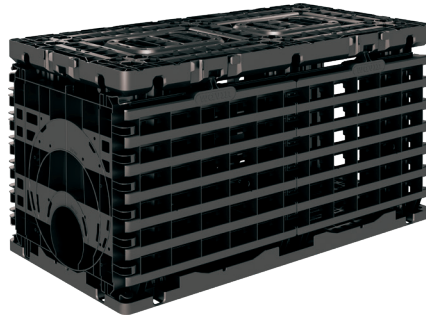

Technical Information

Length	1200
Width [mm]	600
Height [mm]	600
Gross volume [l] (without bottom)	454 (432)
Void ratio [%]	95-96%
Weight main unit [kg]	15,7
Side Plate (nominal weight) (kg)	3,3
Connection Plate (nominal weight) (kg)	1,7
Close Base Plate (nominal weight) (kg)	5,3
Pipe connections [mm]	160 - 500
Shaft connections [mm]	315 - 600
Tank volume per truck [m ³]	<138
Cover depth without traffic load [m]*	0,3 - 4,7
Cover depth with 1 ton wheel load [m]*	0,3 - 4,6
Cover depth with 6 tons wheel load [m]*	0,5 - 4,5

Note: * Resulting from strength based calculation according to EN17152-4 (draft) for single layer systems with well compacted sand, multi layer systems and/or other soil type may reduce the window of application; EN 17152-4 is valid till 0,5m, while for landscaped area and light traffic 0,3m may be applied.

Wavin B.V. | World Trade Center | Wavin Tower F9
Schiphol Boulevard 425 | 1118 BK Schiphol | The Netherlands
www.wavin.com | info@wavin.com



An Orbia business.

Wavin Q-Bic Plus Low Carbon

Technical Information

Accessibility Vertical access [mm]	350 x 240
Width inspection channel [mm]	370
Accessible surface area [%]	77%
General Material	Recycled PP
Color	Black
Interlocking	Integrated
Certifications	EN17152; Certificates pending

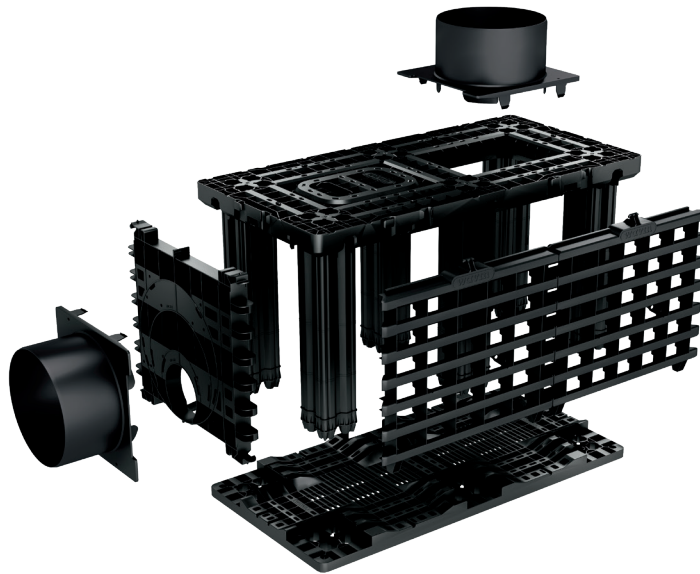

Wavin B.V. | World Trade Center | Wavin Tower F9
Schiphol Boulevard 425 | 1118 BK Schiphol | The Netherlands
www.wavin.com | info@wavin.com



An Orbia business.