

Quick Guide – Product and Installation

Range 315 IC

1 of 4

Description

315mm diameter polypropylene inspection chambers for adoptable and non-adoptable applications. Compliant with Sewers for Adoption 7th edition [SfA7].

Choice of eight base configurations for equal pipe connections.

For use directly with either 110/160mm plastic pipework or 150mm UltraRib system via the appropriate adaptor (6UR141).

315mm diameter shaft may be cut to length to achieve required invert down to a maximum of 2 metres.

Applications

- ⦿ For above ground access and maintenance inspection of buried pipework down to 2 metres deep
 - ⦿ For loading applications:
 - A15 (1.5 tonnes)
 - B125 (12.5 tonnes) *
 - D400 (40 tonnes) *
- * With cover & frame supported by concrete plinth

Key Dimensions

- ⦿ Invert depth of base:
 - 238mm [for 110mm system]
 - 290mm [for 160mm system]
- ⦿ External shaft diameter: 315mm
- ⦿ Shaft length: 2m
- ⦿ Maximum installation depth: 2m

Key Features & Benefits

- ⦿ Fast, easy installation: no wet trades
- ⦿ Lightweight: no lifting equipment required
- ⦿ Reinforcing ribs on underside to withstand groundwater pressure
- ⦿ Shaft can be cut to required length
- ⦿ No additional trench excavation required

Compliance

Range 315 chambers comply with the following standards and regulations

- BS EN 13598-2: 2009 ♡
- SfA7 Typical Chamber Detail – Type 4: (Non-entry. Maximum depth from cover level to soffit of pipe: 2m)
- Building Regulations – Part H1: Shallow only to maximum depth 0.6m



Range 315 Inspection Chamber assembly

This Quick Guide is an extract from brochure (ref OWIC001) Osma + Wavin Inspection Chambers, Product and Installation Manual. The full document is available for download at www.wavin.co.uk



Customer Services:
0844 856 5152

Technical Advice:
0844 856 5165

Website:
www.wavin.co.uk

Email:
technical.design@wavin.co.uk

Quick Guide – Product and Installation

Range 315 IC

2 of 4

Range 315 Chamber and Shaft

NOTE: The following is a summary of installation procedures following selection of a suitable Base for the required number of inlets.

The Range 315 inspection chamber may be installed in the same minimum trench width as required for standard 110mm or 160mm drainage pipework. NO extension of trench width is required.

All elements are lightweight: may be handled/installed by a single person.

Excavation

- Take precautions against trench collapse: support trench sides deeper than 1.2m

Preparation

- Prepare and compact 100mm regulating bed of granular material in trench bottom

Positioning/connection

- Position Base on regulating bed. Check outlet is facing in the correct direction

NOTE: On 34NE300/36NE300 Straight Bases, a flow indication arrow is inscribed

- If connecting to 150mm UltraRib, insert the appropriate adaptors into the required inlet/outlet as follows:
 - 150mm UltraRib use Adaptor 6UR141
- Use standard jointing sequence to connect 100/110mm or 150/160mm pipes to inlets/outlet. Push Blank-off Plugs into any unused inlets

NOTE: The main through channel MUST be used. Bends up to 45° may be used on any inlet or outlet.

Backfill

- Using same material as bedding, backfill around Base in 150mm layers up to underside of shaft socket. Ensure inside of Base is free of debris.

Preparing shaft

- Cut corrugated shaft to approx. Invert depth of Chamber. RECOMMENDATION: leave extra 300mm depth to allow for possible final site changes
- Locate sealing ring between 2nd and 3rd ribs from shaft bottom. Ensure ring is seated correctly/not twisted
- Clean inside of Base socket and lubricate this entire area.
- Position shaft at 45° angle into Base socket. Vertically push home manually or, if required, with mechanical assistance (if so, protect top of shaft)

Backfill trench

- Before starting backfill, cover top of shaft with cap provided

NOTE: If finished ground level is not yet known, leave shaft proud of surface and keep open end covered until final completion.

Figure 15: Typical installation detail: Range 315 Inspection Chamber. Type 4

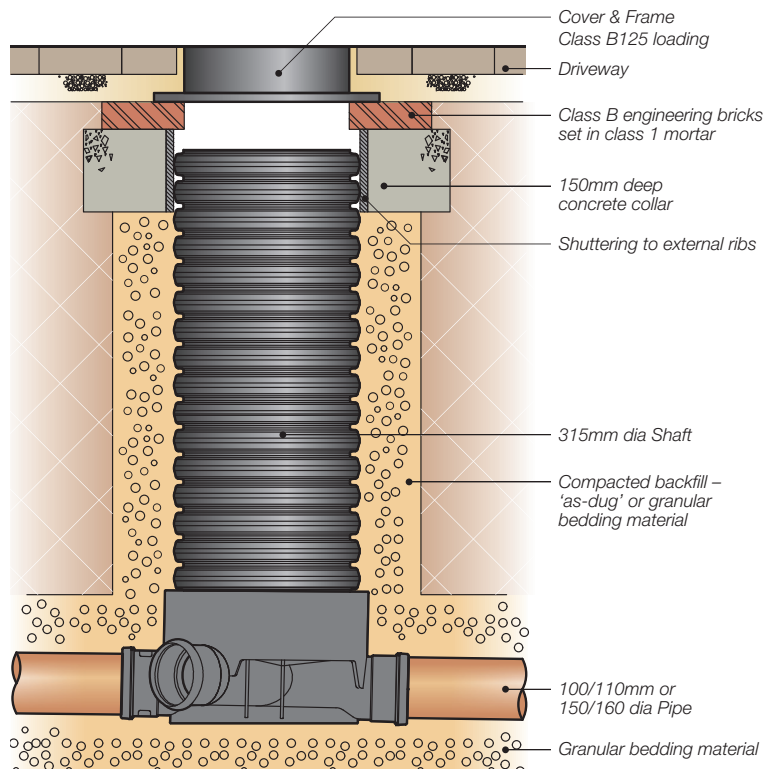

This Quick Guide is an extract from brochure (ref OWIC001) Osma + Wavin Inspection Chambers, Product and Installation Manual. The full document is available for download at www.wavin.co.uk



Customer Services:
0844 856 5152

Technical Advice:
0844 856 5165

Website:
www.wavin.co.uk

Email:
technical.design@wavin.co.uk

Quick Guide – Product and Installation

Range 315 IC

A15 Cover and Frame

A15 polypropylene cover and frames

30NE015 uses a dual fixing system for additional safety. The cover is pre-fixed to the frame using screws.

RECOMMENDATION: use self-tapping screws [not supplied] to secure the frame to the shaft.

For installation in areas not subject to loading, such as domestic gardens, no concrete plinth support is required. (See Figure 16).

For A15 applications subject to occasional/temporary vehicle loading up to 15kN (1.5 tonnes) such as domestic driveways, the frame should be supported by a concrete plinth. (See Figure 17).

Installation procedures:

For green areas and pedestrian areas **NOT*** subject to vehicle loading (See Figure 16)

EXAMPLE: domestic gardens

- ① Trim shaft section at last stage of construction. Ensure unit is at correct height

*For A15 applications subject to occasional vehicle loading up to 15kN (1.5 tonnes) (See Figure 17)

EXAMPLE: domestic driveways

- ① Leave top 150mm of shaft clear of backfill
- ① Lay 150mm thick slab of pre-cast or in situ concrete around top of shaft chamber

Figure 16: Installation detail – green areas (non-loaded)

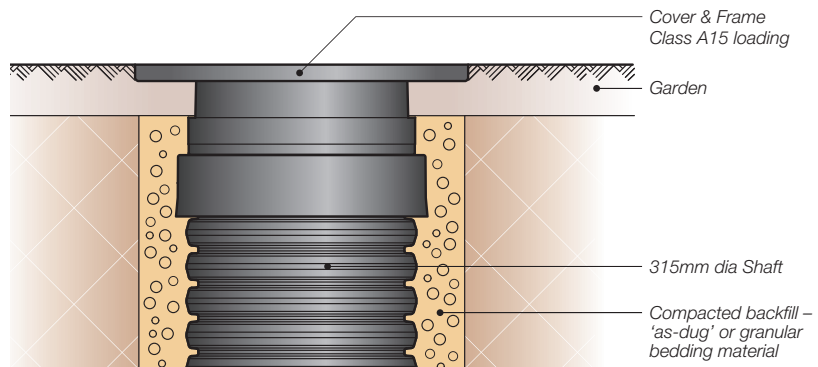
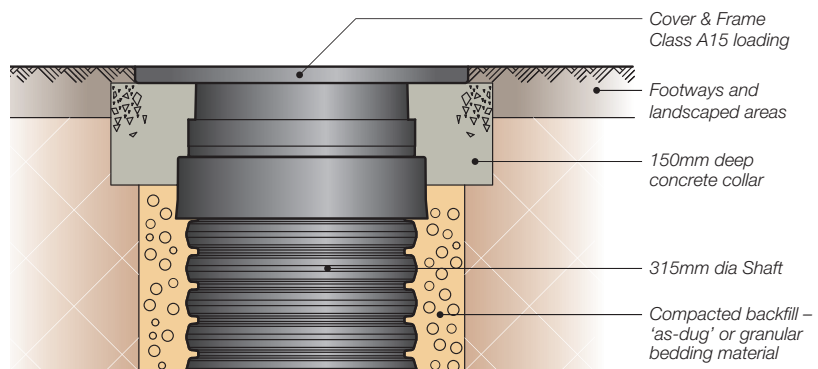

Figure 17: Installation detail A15 – areas subject to occasional vehicle loading up to 15kN (1.5 tonnes)



For all A15 applications

- ① Clean outside of shaft section between first and second rib
- ① Locate sealing ring ensuring it is seated correctly/not twisted
- ① Prepare polypropylene A15 Cover and Frame [30NE015] for installation onto shaft:
 - clean inside of frame socket area
 - apply lubricant to entire surface area
- ① Position the cover and frame socket over the shaft section and push home
- ① Screw frame to shaft using self-tapping screws [not provided]

Quick Guide – Product and Installation

Range 315 IC

4 of 4

B125 & D400 Cover and Frame

Ductile iron cover and frames

Ductile iron options are recommended for heavier loaded applications:

Class B125 – with medium duty loading capacity of 125kN (12.5 tonnes) where the frame is supported by a concrete plinth. Suitable for applications such as car parks and service roads.

Class D400 classification – with loading capability of up to 400kN (40 tonnes) where supported by a concrete plinth. Suitable for carriageways and roads subject to motor vehicle trafficking.

Installation procedures:

For B125 applications (See Figure 18)

EXAMPLE: car parks and service roads

- ④ Trim shaft section at last stage of construction. Ensure unit is at correct height
- ④ Protect shaft from traffic loading by shuttering its external ribs (See Figure 18)
- ④ Lay 150mm thick slab of pre-cast or in situ concrete around top of shaft chamber with minimum opening 450mm x 450mm – or 450mm diameter – to ensure that any loads are distributed away from the shaft
- ④ Position Ductile Iron B125 Cover and Frame on top of slab. (See Figure 18)

Trafficked application (e.g. roadway)

- ④ Follow Highway Specification for installation of a D400 Cover and Frame

Figure 18: Installation detail for B125 loading: paved areas with limited traffic load

