

Product Guide

WAVIN SiTech B1

Low Noise and Low-Flammable

Waste Water Pipe and Fittings



16 dB

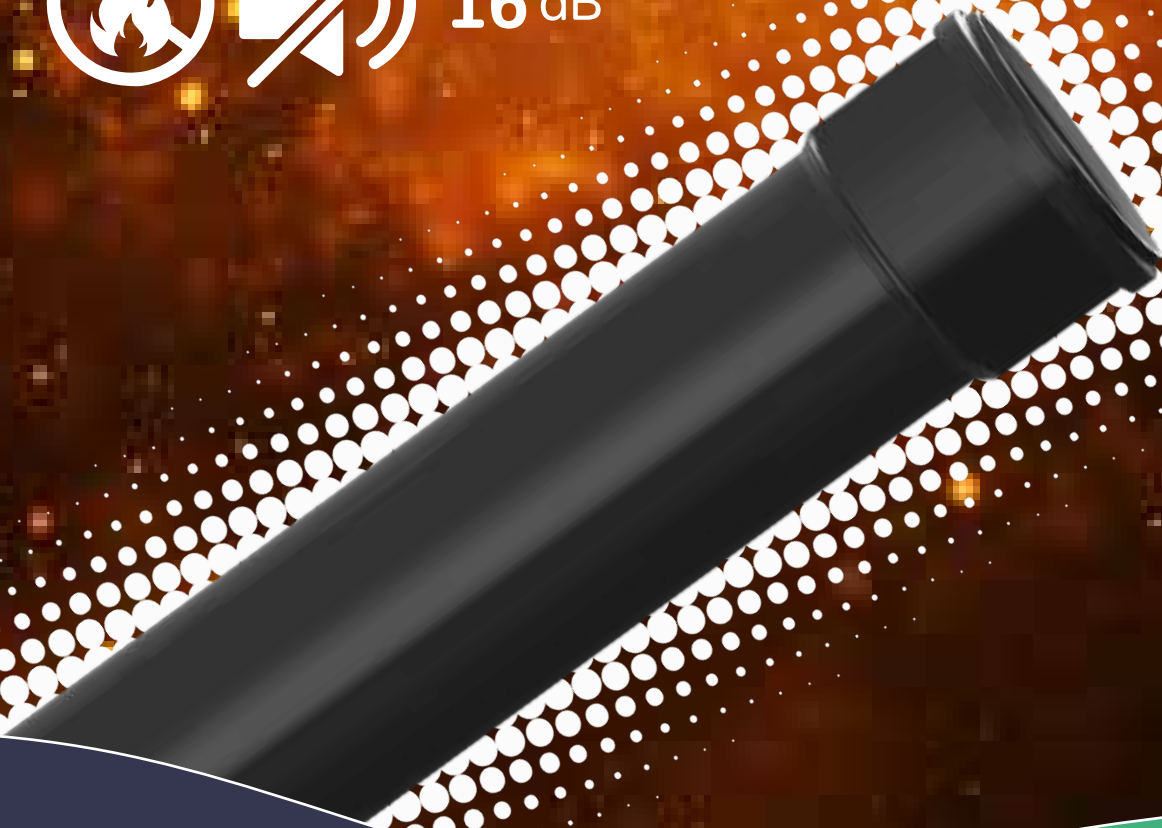

wavin

orbia 

Content

Wavin SiTech BI	3
System description	3
System advantages	3
Field of application	4
Fire regulations	4
Special fittings	5
Technical Datasheet	6
Transportation and Storage	7
Acoustics	8
Advantageous layout	8
Acoustic installation design	9
Installation and jointing	10
Connecting SiTech BI fittings and pipes	10
Cutting pipes to size	10
Fixing	10
General hanging rules	11
Clamp Fixing Instructions	11
Clamp placement	12
Maximum length of threaded rod	14
Increased wall distance	16
Silent suspension - Double clamp – 16 dB(A)	17
Floor ceiling transitions	18
Wavin SiTech BI Product Range	25

Wavin SiTech B1

System Description

Polyvinyl Chloride (PVC) based Wavin SiTech B1 pipes are used in waste water systems. The system provides advanced fire resistance, low sound level and easy installation. With the capabilities of flexible connection and tight fit, SiTech B1 provides a complete solution for waste water drainage in buildings. Life quality and comfort is a significant issue in building design. Reducing of noise in water drainage. The system provides huge comfort both in living and working environments. Wavin SiTech B1 meets today's construction and mechanical application requirements and fulfills customer requests for more comfort and quality. SiTech B1 is designed to meet the requirements of fire code no. 15316.

System Advantages



Fire Resistance

SiTech B1 can be used in all types of waste water projects, including high rise buildings, due to its fire retardant behavior during a fire.



Low Noise

SiTech B1 is a high performance waste water system, reducing the acoustic values of the water flow. The noise coming from the installation is minimized thanks to its special formula.



Angular rotation

There are angular marks for 15 and 45 degrees on fittings. SiTech B1 fittings are rotated and installed easily due to the angular marks on them.

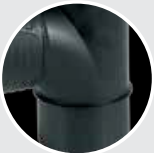

Checking the installation depth

Dashes on spigot ends of fittings allow pipe to fit into the joint exactly. This dash also indicates to the pipe fitter the 10 mm distance required for thermal expansion of long pipes.

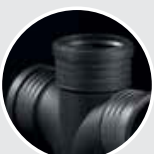

Black Color

The black color contributes to resistance and durability of Sitech B1. Due to enhanced UV resistance to the color black, the system is also highly convenient for external applications. As an addition, the black color furnishes the system with a more aesthetic and professional look.

Application

Wavin SiTech B1 meets all standards specified for waste water discharging systems (EN 1451-1), including noise reduction and fire resistance (EN 13501-1). The level of noise emitted by SiTech B1 was measured by Stuttgart Fraunhofer Institute (DIN 4109, VDI 4100, EN 14366)..

Table 1: Fraunhofer noise level measurement results for SiTech

Test specimen: Wastewater system consisting of straight plastic pipes "SiTech B1 110 x 3.8 PVC-U, 11/08/2020" and fittings "SiTech +, PP-MB" (pipe manufacturer: Wavin Turkey, fitting manufacturer: Wavin Italy) and acoustic pipe clamps with elastic inlay and spacers "Wavin No Noise Bracket" (manufacturer: Walraven GmbH) mounted as acoustic double clamps.		Flow rate [l/s]			
		0.5	1.0	2.0	4.0
Airborne sound pressure level $L_{p,A}$ [dB(A)] according to EN 14366 for the basement test-room	UG front	43	48	50	54
Structure-borne sound characteristic level $L_{v,A}$ [dB(A)] according to EN 14366 for the basement test-room	UG rear	<10	<10	12	16
Installation sound level $L_{inf,A}$ [dB(A)] following DIN 4109 in the basement test-room	UG front	43	48	50	54
	UG rear	<10	13	16	20
Installation sound level $L_{inf,ref}$ [dB(A)] following VDI 4100 in the basement test-room	UG front	41	45	48	52
	UG rear	<10	10	13	16

Wavin SiTech B1 is an ideal solution for installation in high rise buildings and in critical noise places, such as apartment buildings, hotels, hospitals, nursing homes and libraries.

Wavin SiTech B1 can be used for water discharge at temperatures up to 75-80 °C for a short time, and can be used up to 55 °C. Continuously in cold weather, it's resistant up to 0 °C.

The system is available in the following diameters:

- ⦿ 50 mm
- ⦿ 75 mm
- ⦿ 110 mm
- ⦿ 125 mm
- ⦿ 160 mm
- ⦿ 200 mm
- ⦿ 250 mm

You can contact a Wavin Pilsa representative for any questions on the application.

Fire Regulation

With fire regulation no. 15316, issued in 2007 for the first time in Turkey, excluding branch pipes used in wet areas, it has been decreed that installation pipes with a diameter over 70 mm in high rise buildings must be made of low flammable material as a minimum requirement.

With the modification to the regulation in 2009, a high rise building is described as a building with a height of over 21.50 m and structural height over 30.50 m. Structural height includes basement floors in total height. As per the modification on page 44 and item no. 7 of official gazette no. 29411, issued on July 9, 2015; the code allows for the use of normal flammable material if fire collar is used.

According to test measurements of International Efectis Labs, the fire class of Sitech B1 pipes has been identified as B S1 d0 as per EN 13501-1 standard and EN 13823:2014 test method.

Table 2:

Flammability Classes of Building Materials Per TS EN 13501-1

Flammability Classes for Building Materials Excluding Tiles	
Material Flammability	TS EN 13501-1 ⁽²⁾
No Flammability	A1
Low Flammability	A2 - s1, d0
Low Flammability	B, C, s1, d0
	A2 - s2, d0
	A2, B, C - s3, d0
(Minimum)	A2, B, C - s1, d1
	A2, B, C - s1, d2
Normal Flammability	A2, B, C - s3, d2
	D - s1, d0
	D - s2, d0
	D - s3, d0
	E
(Minimum)	D - s1, d2
	D - s2, d2
	D - s3, d2
(Minimum)	E , d2
High Flammability	F
Flammability Classes For Tiling Materials	
Material Flammability	According to TS EN 13501-1 ⁽²⁾
No Flammability	A1 _{FL}
Low Inflammability	A2 _{FL} - s1
Low Flammability	B _{FL} - s1
(Minimum)	C _{FL} - s1
Normal Flammability	A2 _{FL} - s2
	B _{FL} - s2
	C _{FL} - s2
	D _{FL} - s1
(Minimum)	D _{FL} - s2
	E _{FL}
High Flammability	F _{FL}
Flammability Classes for Roofing Products	

Special fittings

The Wavin SiTech B1 portfolio includes specialized fittings for easier and more efficient installation and use, particularly in areas where space is limited. Swept branches, as compared to sharp angle fittings, allow water to run more smoothly while reducing overall noise levels, improve the ventilation and increase the flow rate. The new design of access pipes makes inspection easier.



**Expansion Socket
Access piece**



Access piece



Swept Branch



**Double Swept
Branch**



Shower Branch



Corner Branch

Technical Specifications:

- ⦿ PVC based special formula pipes designed for low noise levels
- ⦿ Low flammable raw material
- ⦿ Socketed connections and elastomer (SBR) gaskets for safe and easy assembly

Table 3: Information per diameter of SiTech B1.

Diameter (DN/OD)	Thickness (s min) (mm)	Socket Length (p2) (mm)	Density (gr/cm ³)
50	3.0	50	1.7
75	3.0	60	1.7
110	3.8	70	1.7
125	4.1	80	1.6
160	4.2	100	1.6
200	4.9	120	1.6
250	6.2	130	1.6

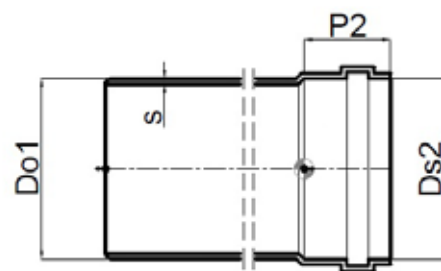

Table 4: SiTech B1 product specifications and standards..

Specifications	Reference Value	Standards
Elongation 150°C - 30 min - in the air	≤ 5%	TS EN ISO 2505
Dichloromethane Resistance 15°C - 30 min	No Deformation	TS EN 580
Fire Behavior	Efectis: EN 13823: C S3 d0 TSE:	DIN 4102-1 TS EN 13501-1
Density (23°C)	Pipe 1,6-1,7 g/cm ³ Attachment: 1.5	TS EN ISO 1183-1
Operating Temperature	Long term 55° C Short term 70°-80°C	
Linear Expansion 20°C - 80°C	0,08 mm/(m.K)	DIN 53752
Water Tightness 23°C, 15 min, 0,5 bar	Sızdırma yok	ISO 13254
Temperature Cycling 93°C/15°C"	Sızdırma yok	ISO 13257
Ring Stiffness 23°C, %3	> 6 kN/m ²	TS EN ISO 9969
Impact Resistance 0°C	TIR ≤ 0	TS EN 744
Vicat Softening Temperature	min 79° C	TS EN 727
Noise Level (*)	16 dbA 16 dbA 20 dbA	VDI 4100 EN 14366 DIN 4109

(*) According to Fraunhofer test results for 4l/s flowrate.



Transportation and Storage

Transport

- ⦿ Handle pipes and fittings with care. Excessive scratching or impact stress on the pipe may damage the external structure or affect the seal properties.
- ⦿ Loose pipes need to be unloaded by hand. When pipes are inserted one inside the other, always remove the inside pipe first.
- ⦿ When bundles of pipes are unloaded by fork truck, we recommend the wrap nylon sheaths around metal forks or use plastic forks. Metal forks, hooks and chains may not come in contact with the pipes. Do not use forks with an extension.
- ⦿ If the loading or unloading is carried out with a crane and excavator arms, the pipes must be raised in the central area with a sling of adequate width.

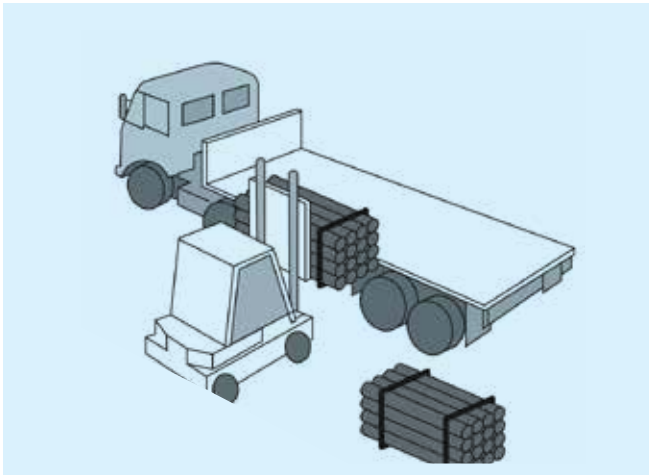
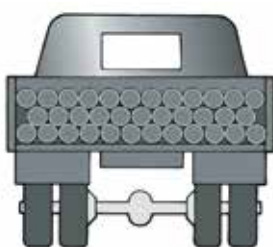

Figure 2: Unloading strapped pallets.

Transportation

- ⦿ Wavin SiTech B1 pipes, when no longer packed in original packaging, must be stored fully supported over their total length on a clean surface during transport.
- ⦿ Bending of the pipes should be avoided.
- ⦿ Impact stress on pipe and fittings must be prevented.



Transport of loose Wavin pipes.

Storage

- ⦿ Always store pipes on a flat surface.
- ⦿ Pallets must be stored at a maximum height of 1.5 m without additional supports or side barriers.
- ⦿ Loose pipes:
 - must have at least 2 side supports equally spread over the pipe length,
 - maximum height of storing loose pipes is 1.5 m.,
 - the ideal situation is to support the loose pipes along their whole length. If this is not possible, place wooden supports of at least 75 mm wide under the pipe at a distance of maximum 1 m.,
 - stack the different sizes of pipes separately or, if this is not possible, stack them with the largest diameters on the bottom,
 - socketed pipes should be stacked in an alternating order to secure support over the full pipe length (see picture.)
- ⦿ Fittings are supplied in carton boxes and must be stored indoors. Deformation resulting from excessive loads on the fittings should always be avoided.
- ⦿ Store lubricant in a cool place, away from heat sources or direct sunlight.

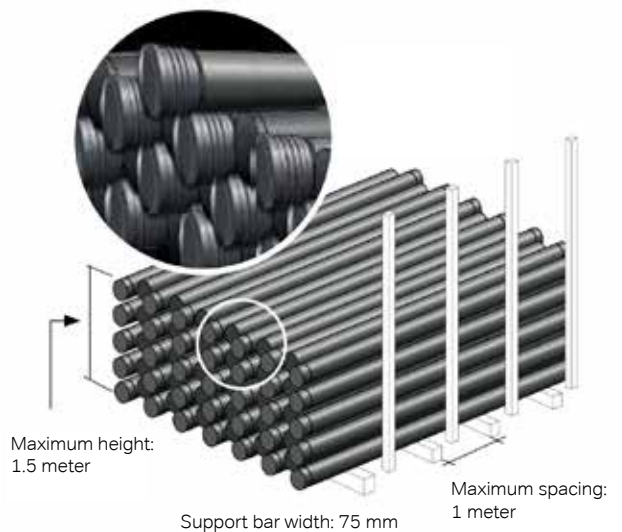

Acoustic

Advantageous layout

An important factor for the assurance of acoustic insulation is the design and implementation of an acoustically advantageous layout.

The following measures have proven to be of significant influence to the level of noise generated from the soil system inside the building:

- ⦿ Noise-sensitive areas should be kept away, as far as possible, from sources of noise.
- ⦿ Non-sensitive areas should, wherever possible, be used as “buffer zones”.
- ⦿ Noise-sensitive areas should not be positioned in the direct vicinity of bathrooms, toilets or stairwells.
- ⦿ Potential sources of noise should be “bundled together” in the same area.

The comparison between the two examples of layout shown above demonstrates how the acoustically advantageous layout in the second example contributes to a clear reduction in the acoustic pressure of the systems in the room which demands acoustic insulation.

However, even using highly efficient low-noise waste systems like Wavin SiTech B1, one always has to seek for the best possible acoustic decoupling. This goes for the whole drainage system and its points of contact with the building (collars, crossings through walls and floors, plaster residues between the pipe and the building, etc...).

In designing piping, moreover, we need to avoid positioning waste pipes in the partition walls between apartments. Special noise-reduction measures also need to be adopted when fixing drain pipes to the partition walls between apartments. Protect the pipes from the propagation of intrinsic noise.

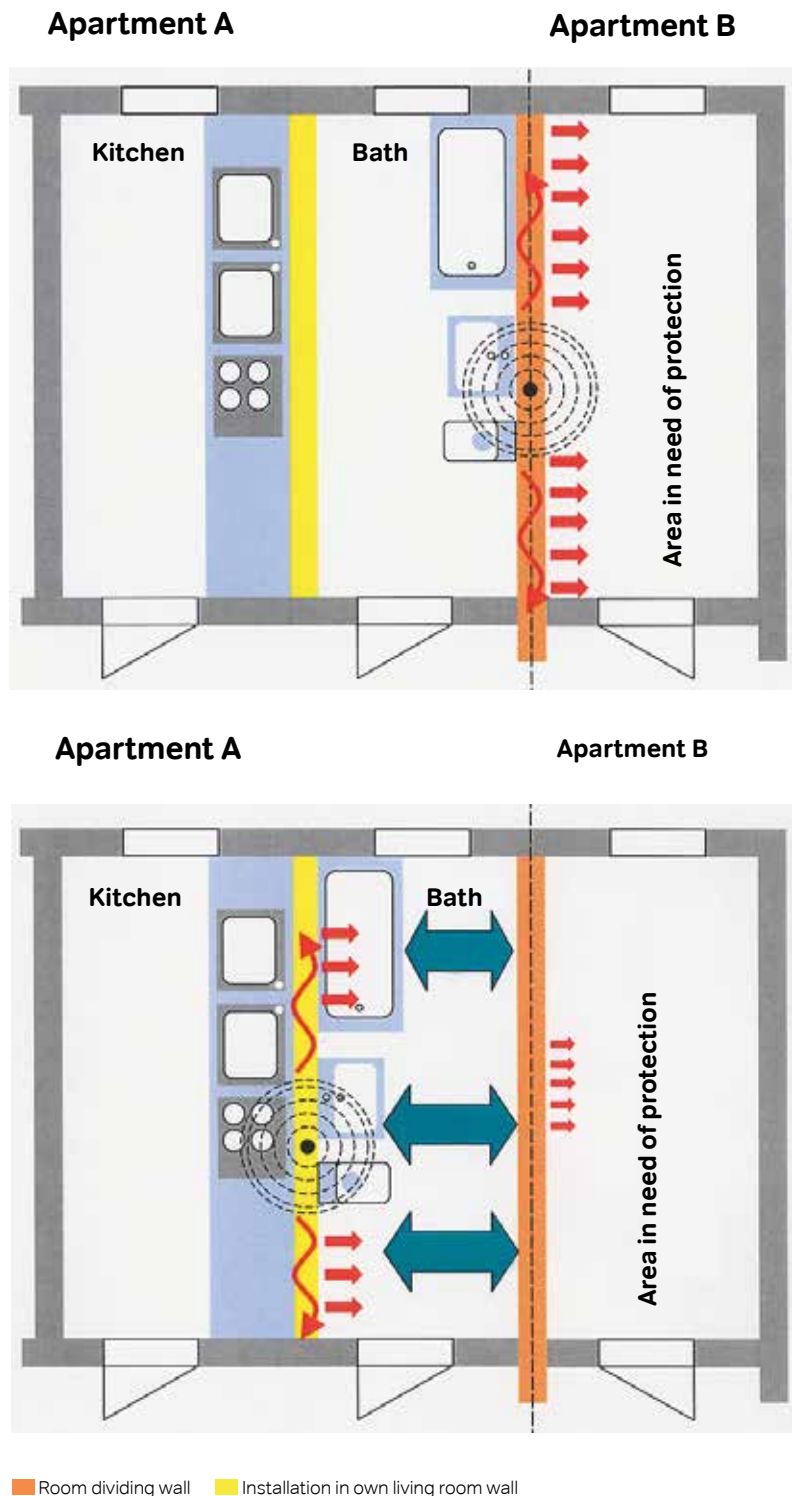

The comparison of the floor plans above demonstrates how good acoustic design in the lower building example can significantly reduce the noise levels to which areas requiring noise protection are exposed.

Fig. 6: Examples of good acoustic practice in building design.

Acoustic plumbing design

Wavin SiTech B1 shows optimal noise performance. However, when installing high-performance sound-insulating waste water piping systems it is still necessary to consider how effectively the system can be sound-isolated. This applies to the waste water discharge system as a whole, including its points of contact with the building structure (pipe brackets and clamps, the running wof pipework through walls and ceilings, mortar droppings between pipes and wall surfaces, etc.).

When planning pipe installation, waste water discharge pipes should not be allowed to run inside the walls separating living areas. The attachment of waste water discharge pipes to partition walls in living areas should only be carried out under application of special noise protection measures. DIN 4109 requires that single-skin walls to which, or in which, water installations or equipment (i.e. waste water pipes) are to be attached must have an area-related mass of at least 220 kg/sq.m. Walls having an area-related mass of less than 220 kg/sq.m may only be used where prior testing has demonstrated that the walls exhibit acceptable properties with respect to the transmission of noise.

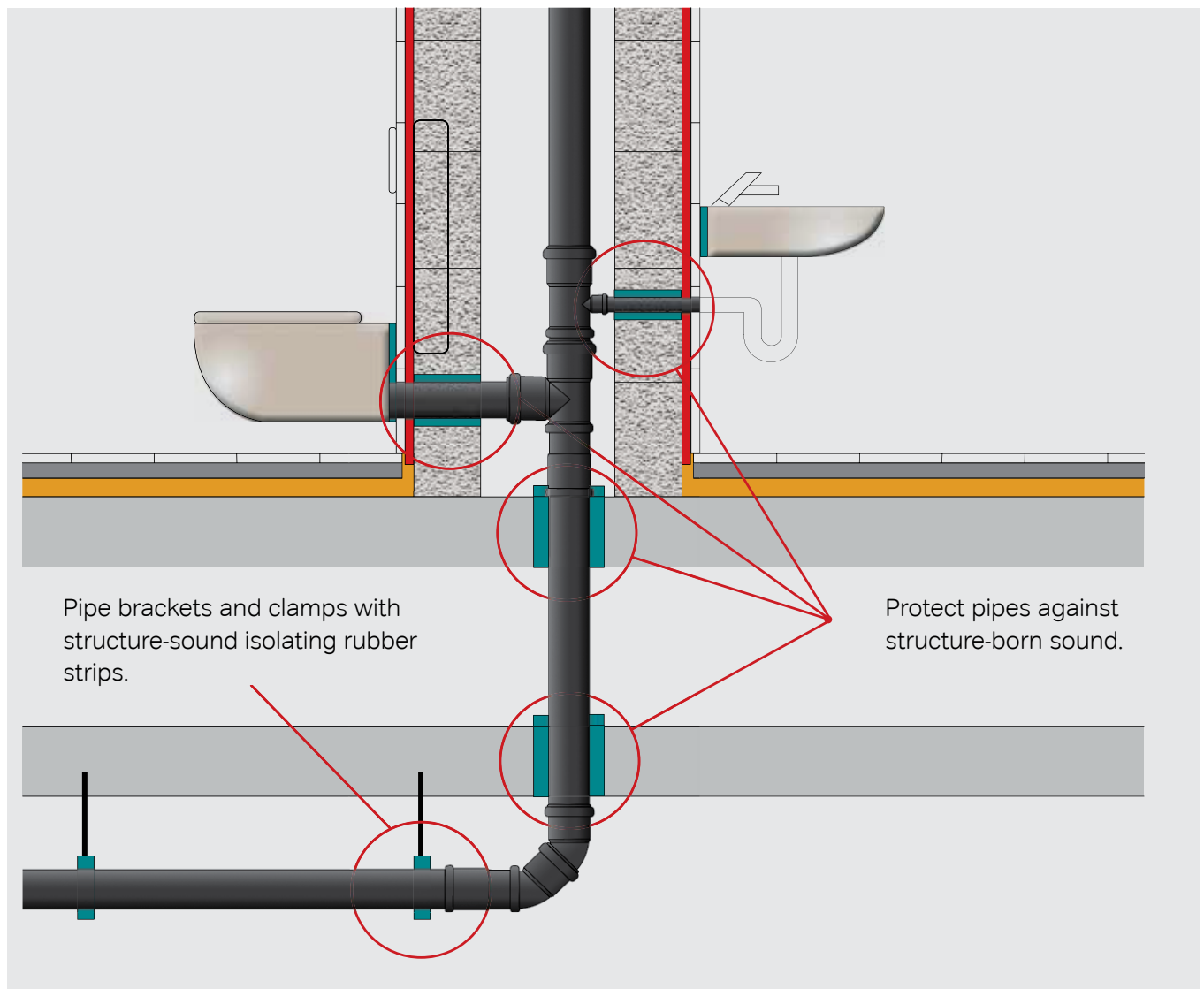

Fig. 7: Sound insulation of waste water systems.

Installation and jointing

Wavin has designed its low-noise systems to reduce noise emissions in concealed and visible installations. However, to ensure the system is leak-tight and to achieve a high level of soundproofing it is strongly recommended to follow the instructions given below.

Connecting Wavin SiTech B1 fittings and pipes

Wavin SiTech B1 connections are fitted as follows:

- ① Check position and condition of the seal in the socket. You may have to clean the socket and the seal.
- ① Clean the spigot-end of the pipe and/or fitting.
- ① In case of pipes : mark the insertion depth (socket length) on the spigot-end.
- ① Push the spigot-end into the socket according the insertion depth.

For pipes ≥ 2 meters:

- ① Pipes & fittings connected to horizontal and vertical pipes ≥ 2 meters to be retracted 10 mm to allow for thermal expansion.
- ① For vertical pipes, directly secure position with brackets to prevent slipping and eliminating the 10 mm dilatation space.

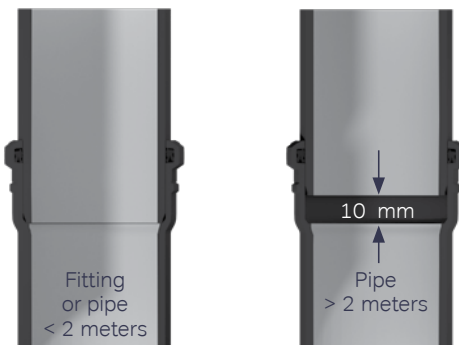

Fig. 8: 10 mm space for thermal expansion.

Cutting pipes to size

Pipes can be cut to size using standard pipe cutters. When cutting pipes to length, do so at an angle of 90° to their axis. Remove any burrs or unevenness from the cut ends and rub down sharp edges.



For connections to Wavin SiTech B1 fittings or sockets the pipe end needs to be chamfered. Its is recommended to chamfer over a length of 5 mm under a 15 degrees angle. This can be done by using standard chamfer tooling.

Fixing

In principle, Wavin SiTech B1 soil and waste water pipe systems should be installed tension-free and able to withstand changes in length. The pipes should be secured with sound-absorbing brackets that are compatible with the external diameter of the pipes and completely surround the circumference of the pipes. We recommend the use of Wavin low noise brackets, designed for securing to the brickwork with screws and plastic wall plugs. Metal anchors may also be used, although these do not favour sound insulation.



General bracketing rules

Bracket Fixing Instructions

Fixed Bracket

The fixed bracket creates a fixed point in the pipe system. The pipe or fitting cannot be moved through the bracket after the screws are tightened (no longitudinal movement is possible).

Use sound absorbing brackets, dimensionally compatible to the pipe diameter. Screw-pipe brackets with rubber inserts are recommended, which are fixed to the wall by screws and plastic plugs.

Sliding Bracket

By using sliding brackets, the pipe can still expand and contract due to temperature changes after the screws are tightened. This make sure longitudinal movement is still possible once installed.

Changing from sliding to fixed

Wavin low noise brackets are usable as sliding and as fixed bracket. All brackets provided by Wavin are sliding as standard.

To change the bracket from sliding to fixed, a distance washer is removed from the bracket before installation. The sliding and fixed brackets can both be completely tightened until the bracket ears touch the distance washers. The distance washers make sure that in any situation, the clamping force on the pipe is perfect. This results in minimal structure borne sound transmission.

The distance washers also prevent over-tightening of the brackets, which could otherwise result in a reduction of sound performance.

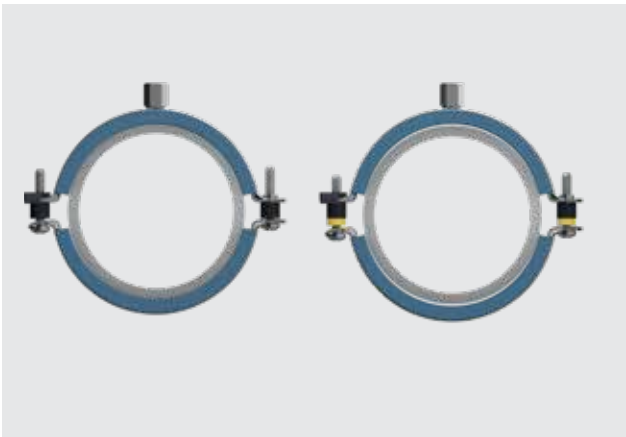

Fixed bracket

* removed distance washer

Sliding bracket

* distance washer in place



Changing from sliding to fixed: Remove the distance washer.



Removable distance washer.

Bracket Arrangement

During installation of Wavin SiTech B1 pipes, the following should be considered:

Vertical pipes:

- ⦿ To prevent the vertical stack sliding down, each pipe section between floors must be secured by one fixed bracket at the spigot-end.
- ⦿ All remaining pipe brackets at subject pipe must be sliding brackets.
- ⦿ The table 2 prescribing the maximum distance between brackets is to be respected.

Horizontal pipes:

- ⦿ Every horizontally installed pipe length ≥ 2 meters should always be fixed with one fixed bracket at the spigot-end.
- ⦿ All remaining pipe brackets at one pipe must be sliding brackets.
- ⦿ The table 2 prescribing the maximum distance between brackets - is to be respected .

Notes:

- ⦿ For all changes of direction - e.g. a bend at the bottom of a down pipe - 1 bracket directly before and after the change of direction.
- ⦿ In case multiple fittings are assembled, additional bracket(s) before/after this assembly might be required to ensure:
 - A downward slope in flow direction is in place (in case of horizontal pipes).
 - The center of the assembly cannot be excessively displaced (in case of vertical pipes).
- ⦿ Ensure the materials are installed tension-free by properly aligning the brackets.
- ⦿ To achieve a high level of sound proofing, generally pipe brackets should not be installed in impact areas (e.g. diameter reductions and changes of directions in the system).
- ⦿ Pipe brackets to be fixed to building materials with high specific area weight.
- ⦿ In multiple storey buildings (from 3 storeys and more) the stack pipes of 110mm must be secured by additional fixing (stack pipe support) to prevent sliding. In this case we advise using the Wavin SiTech B1 socketed short length with a fixed bracket.

Nominal outer diameter DN/OD	Max distance between brackets	
	horizontal	vertical
	(mm)	(mm)
50	750	1250
75	1125	1875
90	1350	2000
110	1500	2000
125	1625	2000
160	2000	2000
200	2000	2000

Table 2: Pipe bracket spacing.

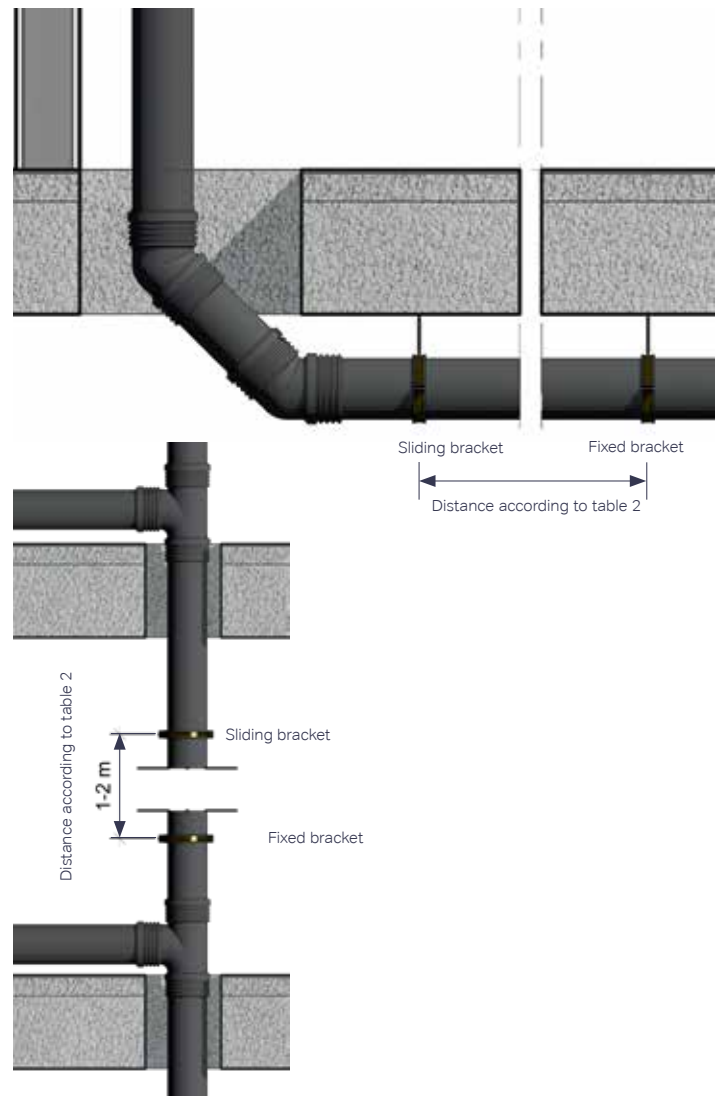

Fig 9: Example horizontal and vertical installation.

Max length of threaded rod

These requirements do not take into account fixation to a wall or ceiling. A proper installation is key to leak-tightness. A poor installation cannot be compensated by a perfect system. Threaded rods are commonly used for suspension and fixing pipe brackets. It is important to keep in mind that threaded rods are designed to be used in tension and not to withstand bending moments.

For this reason, threaded rods to be used in SiTech B1 installations have predefined maximum lengths. If the strength class is unknown, the maximum length can be retrieved from Table 3a and 3b. These tables were created, based on strength class 4.6.

Regarding internal pressure it is important to know what the impact can be in case maximum lengths are exceeded. In case the system gets clogged or otherwise is filled with water, an internal pressure builds up, the resulting forces cause the rods to bend and the joints might be pushed apart till leakage occurs.

The maximum pressure that can occur when the system gets clogged is determined by the vertical distance between the horizontal line and the lowest sanitary application to which this horizontal line is connected. In most cases, this distance is ≤ 1 meter.

Therefore, the maximum lengths of the threaded rods in Tables 3a and 3b are such that they can withstand bending moments due to 0.1 bar internal pressure.

In the following cases, a heavier fixation needs to be applied – especially at changes of direction where resulting forces cause threaded rods to bend – to ensure the system remains leak-tight.

- ⦿ The distance between bracket and wall / ceiling exceeds the maximum lengths as given in the table.
- ⦿ The maximum pressure in the system can exceed 0.1 bar in case of clogging.
- ⦿ There is a wish to hydrotest the installed system at a pressure > 0.1 bar.

In these cases it is advised to follow the method of statement for soil & waste pressure testing procedure or consult Wavin or bracket supplier.

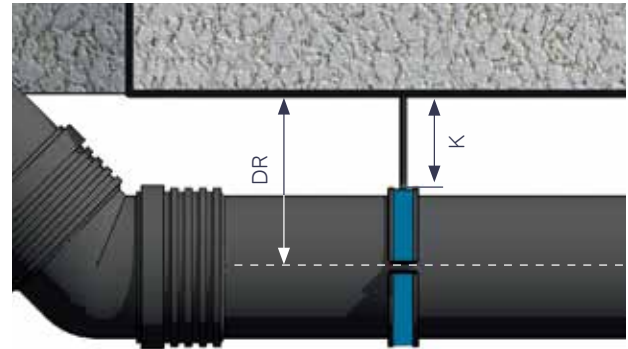

Horizontal

Maximum (DR) distance to the ceiling and maximum length (K) of threaded rod or threaded pipe

	M8		M10		M12		1/2"		1"	
	DR	K	DR	K	DR	K	DR	K	DR	K
DN/OD50	120	85	195	160	315	280	1535	1500	1535	1500
DN/OD75	110	60	170	120	260	210	1300	1250	1550	1500
DN/OD90	105	50	150	95	225	170	1055	1000	1555	1500
DN/OD110	105	40	145	80	205	140	915	850	1565	1500
DN/OD125	100	30	135	60	180	105	725	650	1570	1500
DN/OD160			135	45	175	85	590	500	1590	1500
DN/OD200			150	40	175	70	510	400	1360	1250

Note: for M12 threaded rods, 1/2" and 1" threaded pipes, adapter pieces are needed to connect to brackets.

Table 3a: Fixing distance to the wall - Horizontal.

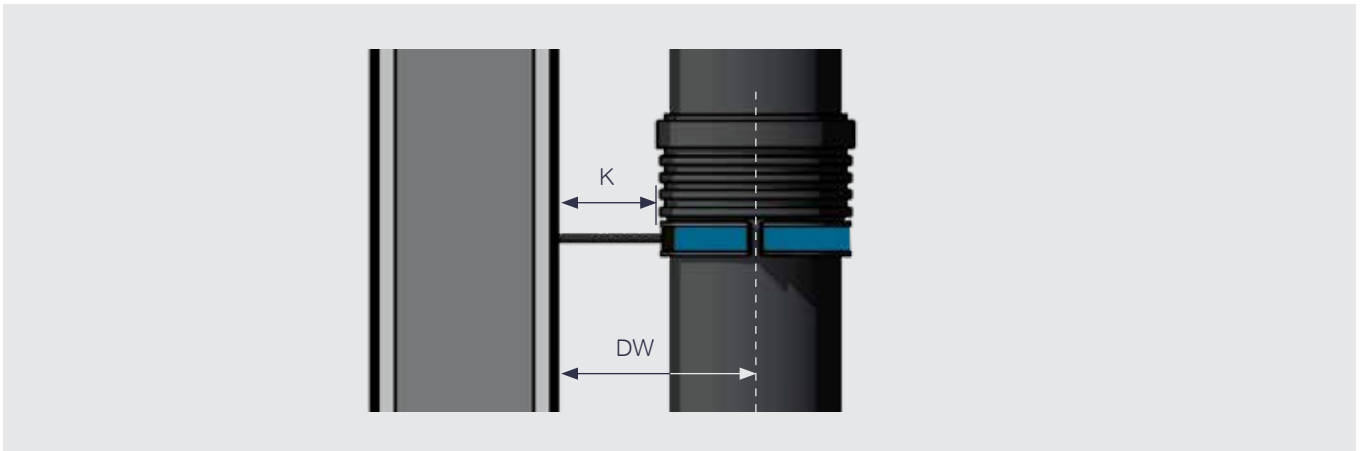

Vertical

Maximum (DW) distance to the wall and maximum length (K) of threaded rod or threaded pipe

	M8		M10		M12		1/2"		1"	
	DW	K	DW	K	DW	K	DW	K	DW	K
DN/OD50	95	60	155	120	245	210	1285	1250	1535	1500
DN/OD75	90	45	130	85	195	150	895	850	1545	1500
DN/OD90	85	30	115	60	165	110	705	650	1555	1500
DN/OD110			115	50	150	85	565	500	1565	1500
DN/OD125			105	35	140	70	470	400	1320	1250
DN/OD160			120	30	140	50	390	300	1090	1000
DN/OD200					150	40	370	260	960	850

Note: for M12 threaded rods, 1/2" and 1" threaded pipes, adapter pieces are needed to connect to brackets.

Table 3b: Fixing distance to the wall - Vertical.

4.2.4. Extended wall distance

If the distance from the wall to the pipe is bigger than you can solve with a single threaded rod according to the table 3a and 3b with the general fixing distances, or in case the internal pressure might exceed 0,1 bar then there are multiple options to increase the distance.

It is important to know what the impact can be in case maximum lengths are exceeded. In case the system gets clogged, an internal pressure builds up, the resulting forces cause the rods to bend and the joints might be pushed apart till leakage occurs. In these cases the following options could be considered:

1. An option could be to consider suspended bracketing for socket support. Bracket assemblies are available for suspended sanitary and drainage installations in a building.
2. Another option is to use a 'wall bracket' to extend the distance between wall and pipe.
3. A third option could be to mount the pipe brackets to a mounting rail, that is installed parallel to the complete installation of the pipe.
4. A fourth option could be securing the connection via a LKS clamp. The joints at changes of flow direction need to be secured to prevent them from detaching. The Wavin LKS clamp guarantees this for internal pressures of up to 2 bar.

Low noise installation – bracketing types

Low noise installation is all about minimizing the transfer of sound (vibration) to connecting rooms. Two types of sound can be distinguished; airborne and structure borne sound. Airborne sound is reduced by the mass of the SiTech B1 pipe, and structure borne sound is reduced by low noise bracketing. For more information about noise reduction, please refer to chapter acoustics.

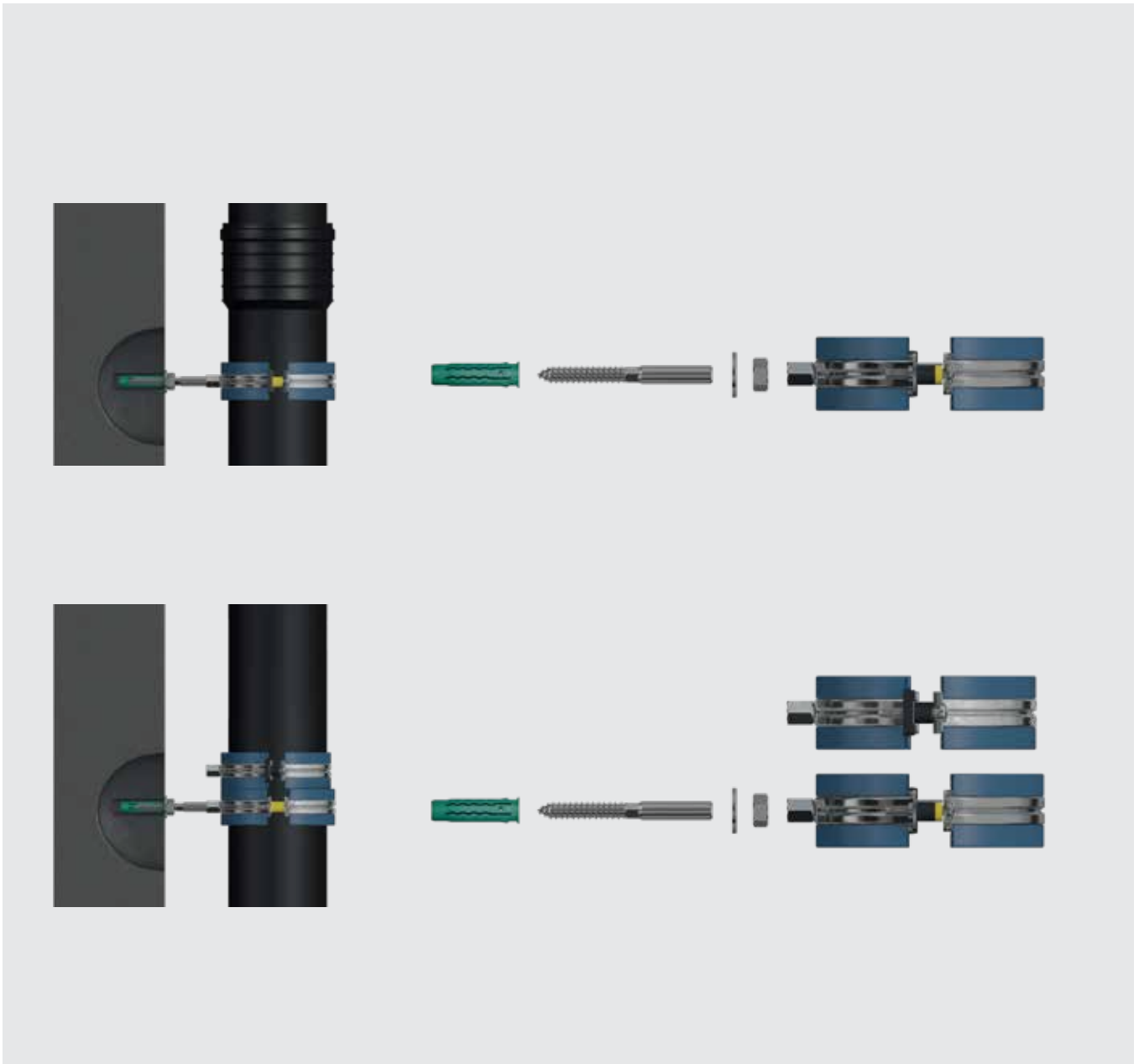

Fig. 10: Low noise bracketing – 21dB (A).

Floor and ceilings crossings

- ⦿ Floor and ceiling crossings must be made both moisture-resistant and soundproof using e.g. mineral wool or foam material.

Shower branch

- ⦿ For an economic and easy installation of a toilet and waste pipes separately to the soil stack you can use a Shower branch (1).

Tensile resistant connection

Gravity drainage systems (for rain or waste water) can be subject to both planned and unplanned pressure surges. If Wavin SiTech B1 is used as a pressure line for a pump station, for example, the resulting pressure surges are planned. If an overloaded rainwater pipe is subject to hydrostatic pressure, however, this counts as an unplanned pressure surge.

For both types of pressure surge, the joints at changes of flow direction need to be secured to prevent them from detaching. The Wavin LKS clamp guarantees this for internal pressures of up to 2 bar.

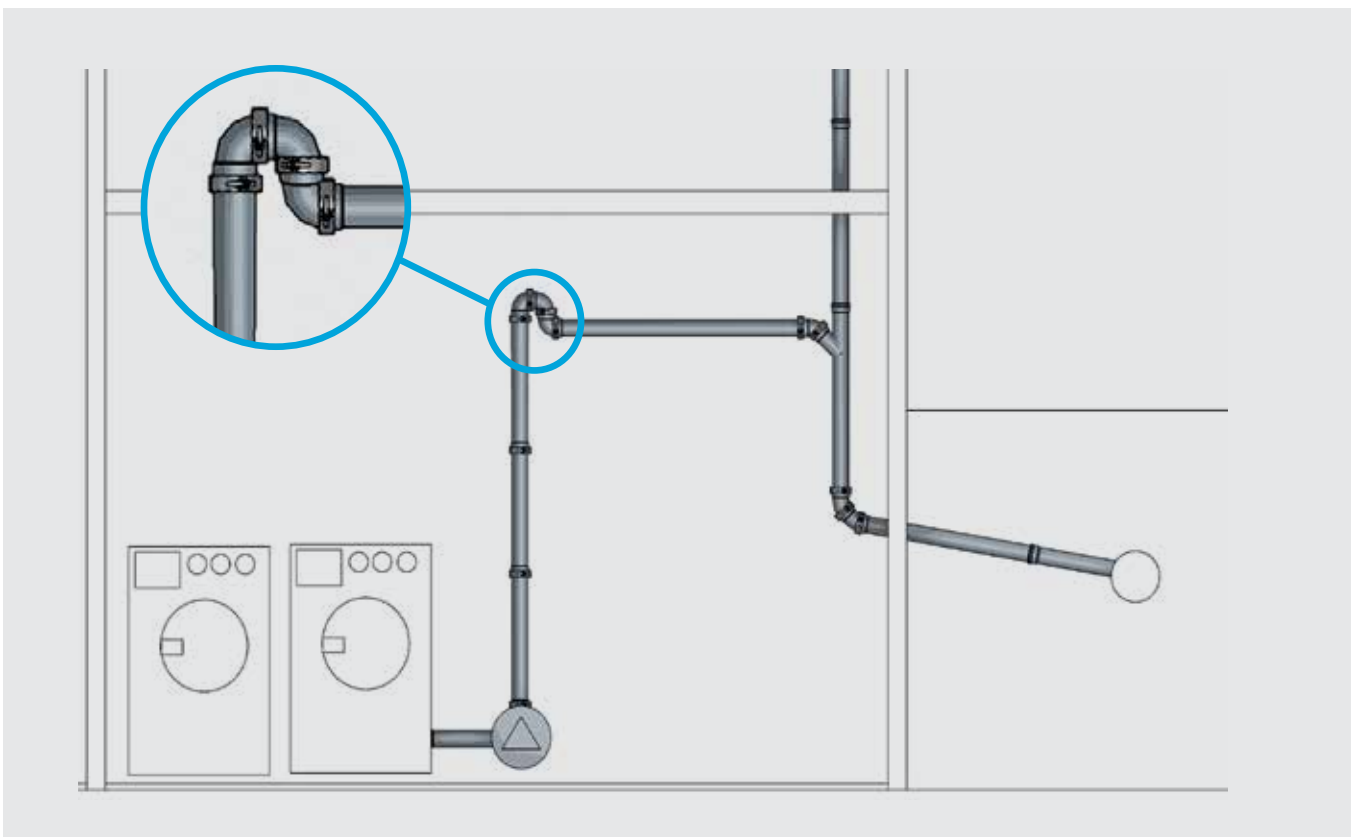
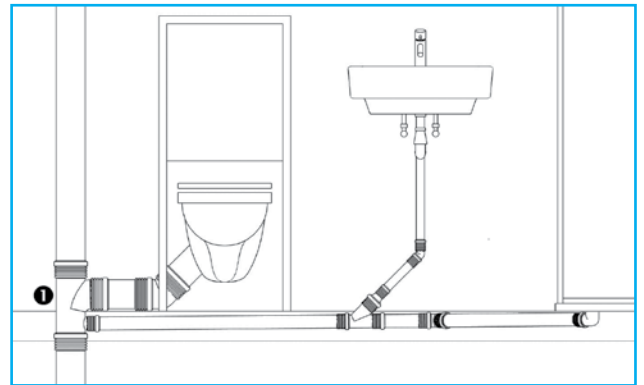
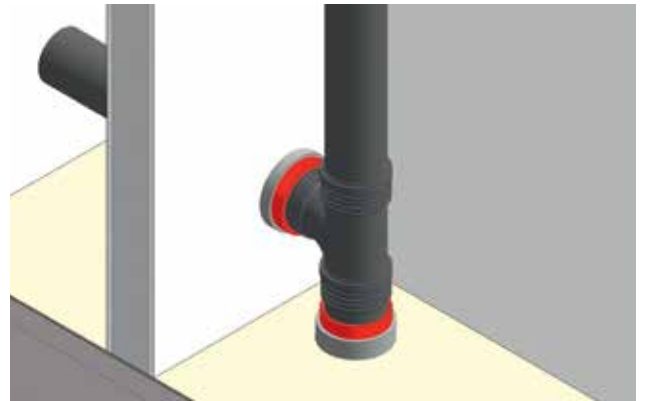

Fig. 12: Tensile resistant connection.

Pressure surges may occur in any part of systems located downstream of pumps and pump stations. All fittings should therefore be secured using LKS clamps. Ensure that the fixings used are able to withstand such pressure surges. The system must be able to transfer dynamic loads to the supporting structure.

In the case of rainwater drainage systems, fittings located at changes of direction are critical. These fittings must therefore be equipped with LKS clamps. Vertical pipes (downpipes) do not require separate LKS clamps. Provided that the fixing specifications provided by us in this manual are observed, the joints on these sections will be suitably secured by the LKS clamp fitted where the change of direction occurs.

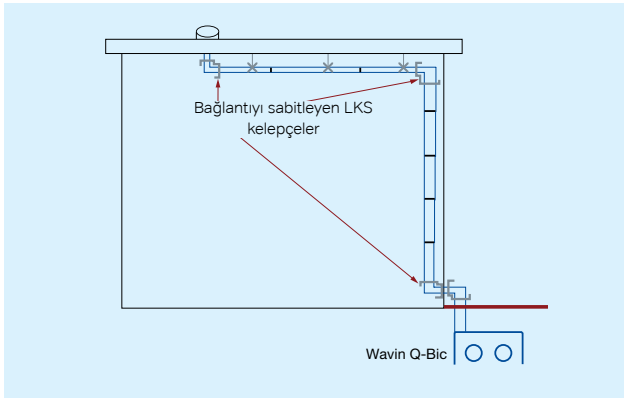

Fig. 13.

Wavin LKS clamps are available for use with SiTech B1 in sizes 32 mm up to 160 mm.

For details of the required collar sizes and corresponding article numbers, please refer to page 50 of our SiTech B1 range.

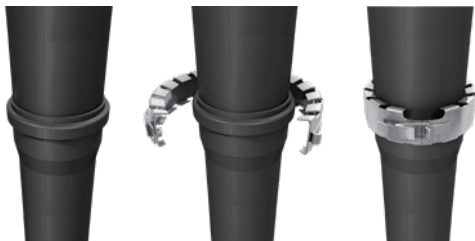

Fig. 14: Wavin LKS Clamp.

Soundproofing

If interior spaces are subject to the technical provisions of DIN 4109 (sound insulation in buildings), with pipe-borne noise not exceeding 30 dB(A), all work must conform to the technical building regulations applying to in-building systems with res-

pect to the configuration of pipes in the context of the corresponding floor plan. Waste water pipes that run through living areas must not be exposed. If they are to run adjacent to such living areas, they may only be installed inside walls with a minimum specific area weight of 220 kg/m² (See DIN 4109-5).

The same conditions apply when installing in brickwork recesses conforming to DIN 1053, with pipes running along the other side of an adjacent wall subject to protection measures, where minimum wall dimensions of 220 kg/m² apply in the area of the recess. Shafts or recesses in brickwork must then be fitted with a supporting structure (matting or metallic mesh) that allows them to be plastered over to a minimum depth 1.5 cm. There must be no sound bridges between the pipe and plaster covering. Preventive measures in this respect include pipe lagging of material classes A1, A2, B1, B2 (e.g. glass fibre, mineral wool or plastic).

As the routing of the pipe has a considerable influence on both the generation and reduction of noise, measures should be taken to minimise its impact. Falling waste water should therefore be directed downwards in stages where possible, i.e. not abruptly, as this would be technically unfavourable. In the case of buildings with more than three storeys (> 10 m), a noise-damping length of 250 mm is fitted between the down-pipe and the horizontal pipe. This can take the form of two 45° bends and a corresponding length of pipe (see Fig. 15).

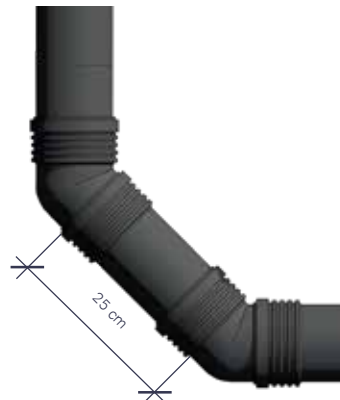

Fig. 15: Extended 45° bend.

Alternatively, the use of one extended 45° bend and one normal 45° bend is recommended. The waste water pipes should likewise be dimensioned and installed in such a way that allows air to circulate freely around the water being drained. Pipe clamps designed to comply with noise-prevention requirements must be fitted with a suitable rubber insert. In the case of bricked-up pipes, note that these must be secured to the underlying structure and not to the new brickwork. Wall and ceiling penetrations must be flexible.

Repairs using repair couplers

If a pipe section needs to be replaced or a branch needs to be added to the pipe system, please follow the following procedure..

1. Cut out the part which needs to be replaced. When inserting a branch at a later stage, please secure that the level of the branch is located at the right height. The Z1 value is mentioned for each branch in the product overview.

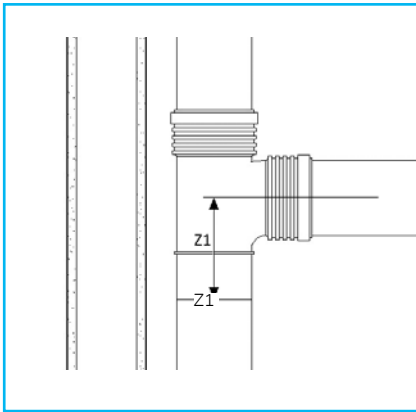

2. Install a short piece of temporary pipe halfway onto the repair coupler to secure a correct positioning of the rubber seal.
3. Install the free half of the coupler onto the existing pipe and slide the repair coupler completely over the existing pipe.

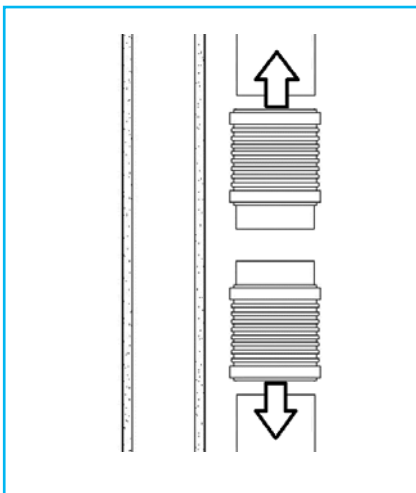

4. Secure that the pipe (or pipe and Branch) has the same length as the part which has been cut out.
5. Measure half of the repair coupler length. Measure the same length from the new pipe ends and mark the pipe.
6. Install as close as possible to the two pipe ends wall plates for the fixed-point brackets and mount the threaded rod and back part of the brackets. When fixing the repair couplers with tensile resistant clamps this step can be skipped.

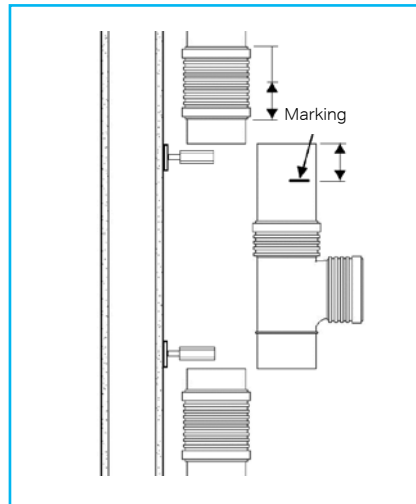

7. Install a tensile resistant clamp on each repair coupler to ensure no movement.

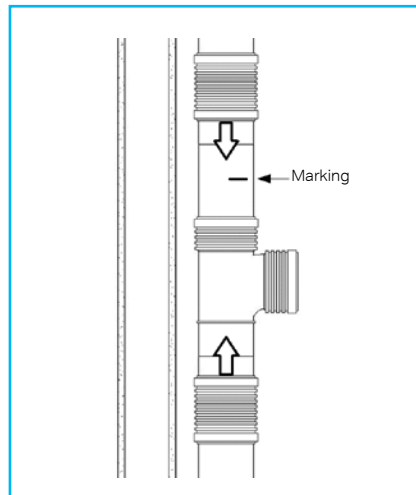

8. Finalise the installation of the fixed-point brackets or install a tensile resistant clamp on each repair coupler to ensure no movement..

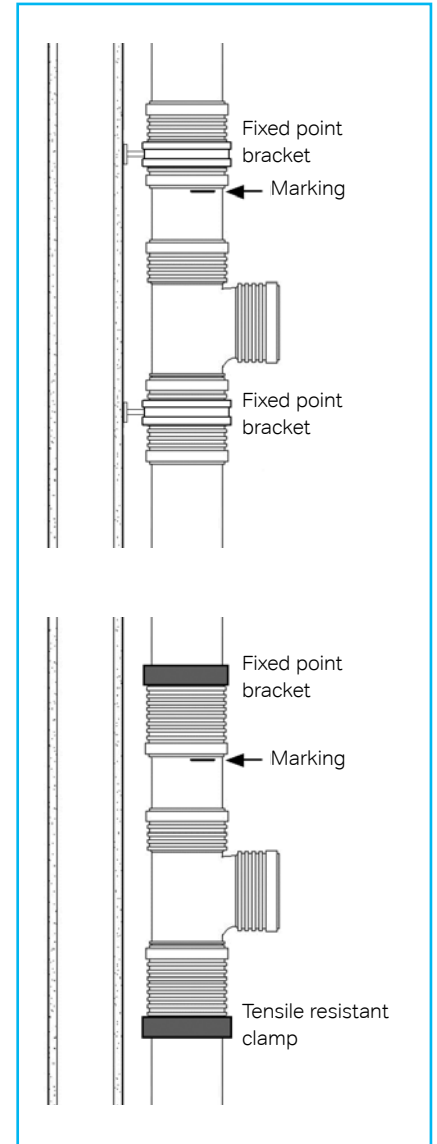

Repairs using a long socket and repair coupler

1. When inserting a branch at a later stage, please secure that the level of the branch is located at the right height. The Z1 value is mentioned for each Branch in the product overview.

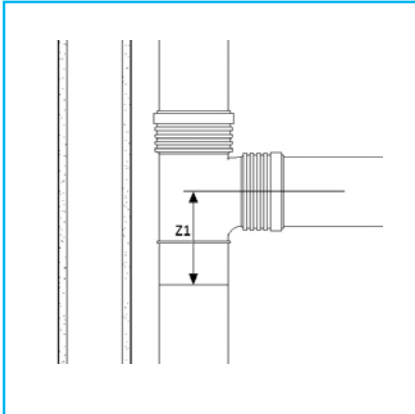

2. When inserting a branch, the length of the part to be cut out should have the length of the branch (L) + 20 mm + the length of the spigot of the long socket (Q).

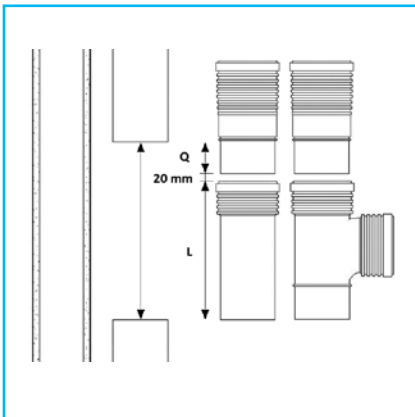

When replacing a piece of pipe, secure that the total length of the new socketed pipe (L) equals the length of the part cut out minus the length of the spigot of the branch (Q) minus 20 mm.

3. Install close to the two pipe ends wall plates for the fixed-point brackets and mount the threaded rod and back part of the brackets. When fixating the repair couplers with tensile resistant clamps this step can be skipped.

4. Install a short piece of temporary pipe halfway onto the repair coupler to secure a correct positioning of the rubber seal.

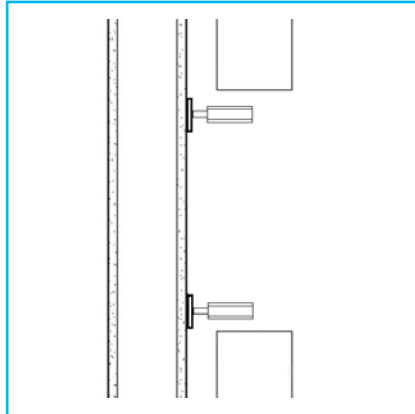

5. Install the free half of the coupler onto the existing pipe and slide the repair coupler completely over the existing pipe.

6. Slide the long socket over the other pipe end.

7. Push the socketed of the branch or pipe on to the long socket.

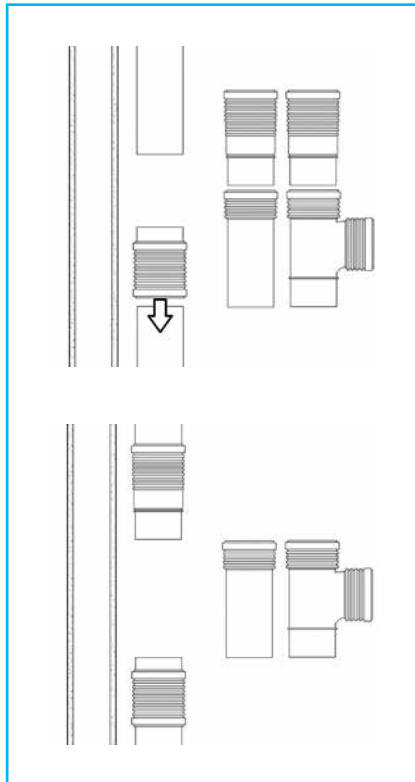

8. Push the long socket with the branch or pipe till the two pipe ends meet.

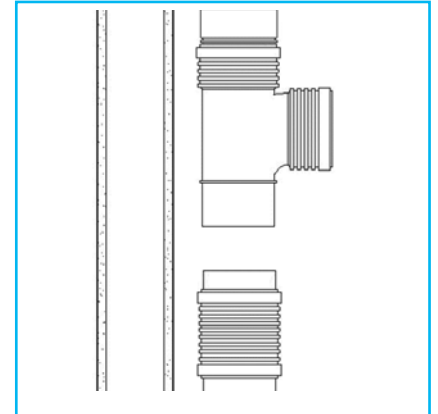

9. Finalise the installation of the fixed-point brackets or install a tensile resistant clamp on the long socket to ensure no movement.

10. If a pipe is inserted, measure half of the repair coupler length. Measure the same length from the new pipe end and mark the pipe.

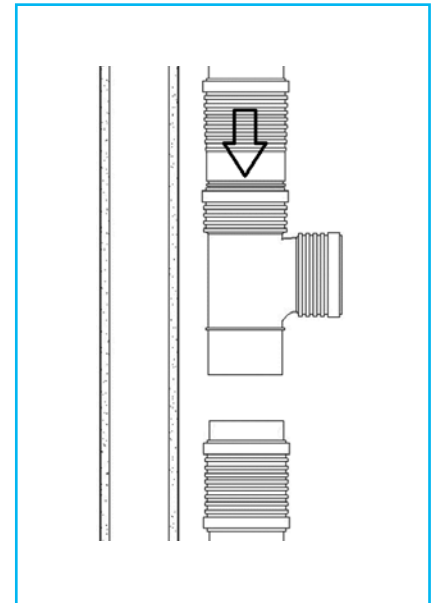

11. Slide the repair coupler over the spigot end of the branch or to the marking on the pipe.
12. Finalise the installation of the fixed-point bracket or install a tensile resistant clamp on the repair socket to ensure no movement.

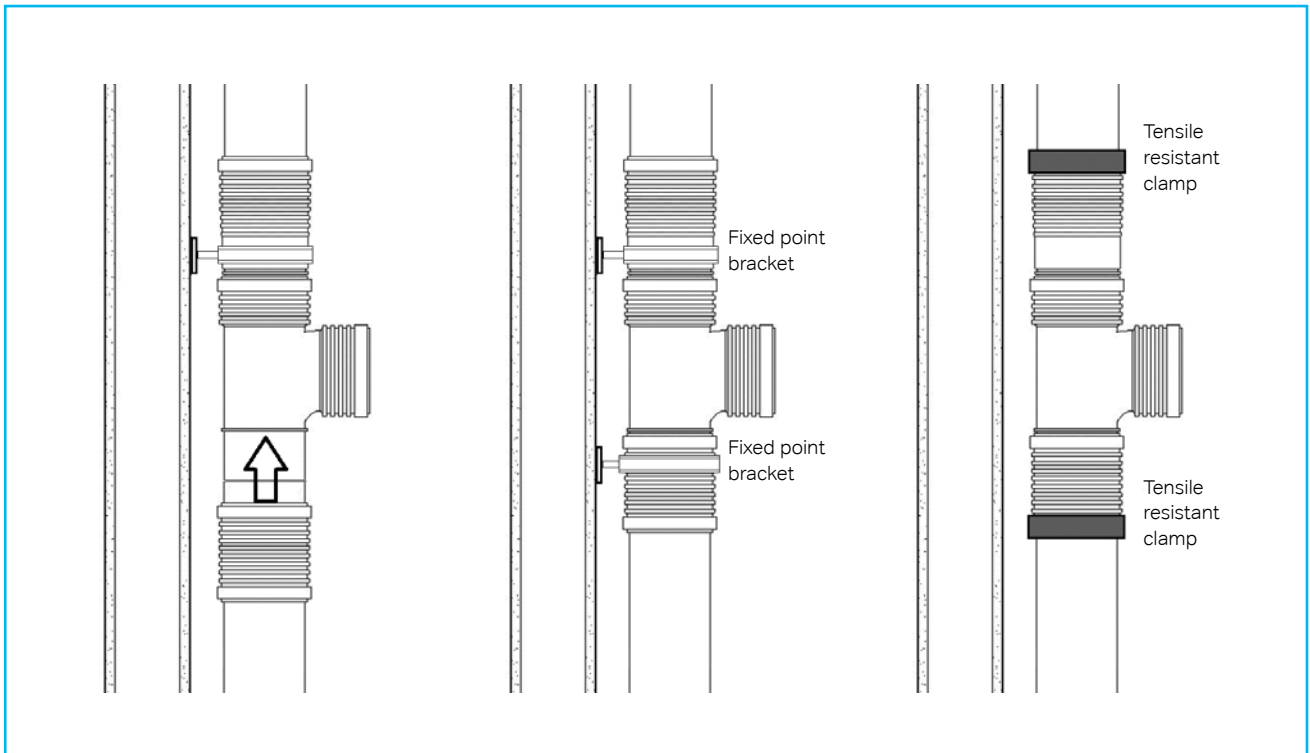

Wavin SiTech B1 / Product Portfolio

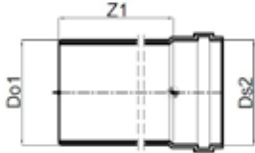

SiTech B1Pipe (PVC-U)

SAP Code	Diameter mm	Do1=Ds2 mm	Z1 (Size) mm
3071725	50	50	150
3071726	50	50	250
3071727	50	50	500
3071728	50	50	1000
3071809	50	50	2000
3071810	50	50	3000
3071811	75	75	150
3071812	75	75	250
3071813	75	75	500
3071814	75	75	1000
3071815	75	75	2000
3071816	75	75	3000
3071817	110	110	150
3071818	110	110	250
3071819	110	110	500
3071820	110	110	1000
3071821	110	110	2000
3071822	110	110	3000
3071823	125	125	150
3071824	125	125	250
3071825	125	125	500
3071826	125	125	1000
3071827	125	125	2000
3071828	125	125	3000
3071829	160	160	250
3071830	160	160	500
3071831	160	160	1000
3071832	160	160	2000
3071833	160	160	3000
3071834	200	200	3000
3083521	250	250	3000

Wavin SiTech B1 / Product Portfolio

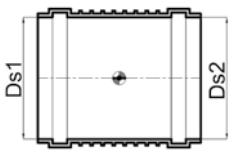

Sleeve

SAP Code **Diameter mm** **Ds1=Ds2 mm**

3067791	50	50
3067792	75	75
3067794	110	110
3067795	125	125
3067796	160	160
3071070 (*)	200	200

(*) It is manufactured from PVC in black color.



Repair/Extension Muff

SAP Code **Diameter mm** **Do1=Ds2 mm** **Z1 mm** **Z2 mm**

3074809	50	50	52	56
3085676	75	75	59	64
3067809	110	110	152	79
3074812	125	125	171	91
3074813	160	160	187	99

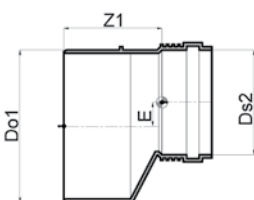

Long Eccentric Reduction

SAP Code **Diameter mm** **Do1 mm** **Ds2 mm** **Z1 mm** **E mm**

3067815	75	75-50	50	77	12
3067816	110	110-50	50	106	27
3067817	110	110-75	75	98	17
3067818	125	125-110	110	98	7
3067819	160	160-110	110	121	24
3067820	160	160-125	125	117	16
3071069 (*)	200	200-160	160	130	16

(*) It is manufactured from PVC in black color.

Wavin SiTech B1 / Product Portfolio

Elbow

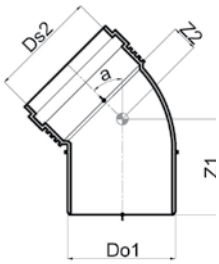

SAP Code	Diameter mm	Do1=Ds2 mm	Z1 mm	Z2 mm	a °
3067726	50x45°	50	65	17	45
3067727	75x45°	75	75	22	45
3067729	110x45°	110	96	33	45
3067730	125x45°	125	105	38	45
3067731	160x45°	160	121	48	45
3079672 (*)	200x45°	200	147	75	45
3067741	50x87.5°	50	78	31	87.5
3067742	75x87.5°	75	95	45	87.5
3067744	110x87.5°	110	128	64	87.5
3067745	125x87.5°	125	141	74	87.5
3067746	160x87.5°	160	166	94	87.5
3070673 (*)	200x87.5°	200	195	127	87.5

(*) Manufactured from PVC in black color

Single Branch

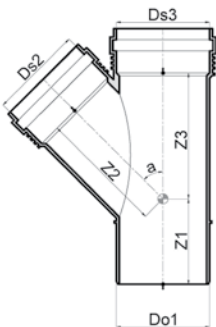

SAP Code	Diameter mm	Do1=Ds3 mm	Ds2 mm	Z1 mm	Z2 mm	Z3 mm	a °
3095062	50-50 x 45°		50	50	64	71	45
3067752	75-50 x 45°		75	50	56	82	45
3067753	75-75 x 45°		75	75	74	96	45
3067757	110-50 x 45°	110	50	63	105	93	45
3067758	110-75 x 45°	110	75	71	122	113	45
3067760	110-110 x 45°	110	110	108	138	138	45
3067761	125-75 x 45°	125	75	70	133	121	45
3067762	125-110 x 45°	125	110	95	149	146	45
3067763	125-125 x 45°	125	125	106	156	156	45
3067764	160-110 x 45°	160	110	82	175	164	45
3067765	160-160 x 45°	160	160	120	200	200	45
3070903 (*)	200-200 x 45°	200	200	140	250	253	45
3067774	50-50 x 87.5°	50	50	82	35	36	87.5
3067775	75-50 x 87.5°	75	50	82	45	35	87.5
3067776	75-75 x 87.5°	75	75	95	49	49	87.5
3067778	110-50 x 87.5°	110	50	96	63	37	87.5
3067779	110-75 x 87.5°	110	75	109	66	52	87.5
3067780	125-110 x 87.5	125	110	133	77	71	87.5
3067781	125-125 x 87.5°	125	125	141	80	79	87.5
3074213	160-110 x 87.5°	160	110	165	103	103	87.5
3074214	160-160 x 87.5°	160	160	165	111	101	87.5

(*) Manufactured from PVC in black color

Wavin SiTech B1 / Product Portfolio

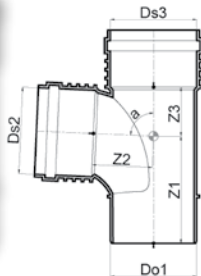

Wide Angle Single Branch

SAP Code	Dimension mm	Do1=Ds2	Ds2 mm	Z1 mm	Z2 mm	Z3 mm	a °
3067835	110-110 x 87.5°	110	110	144	143	64	87,5



Shower Branch

SAP Code	Dimension mm	Do1=Ds3 Ds4	Ds2 mm	Z mm	Z1 mm	Z2 mm	Z3 mm	Z4 mm	a °
3071187	110-110-50 x 87.5°	110	50	111	96	63	79	64	87,5

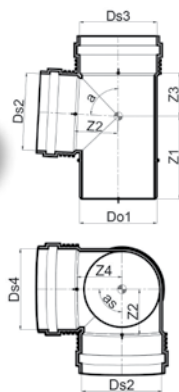

Corner Branch

SAP Code	Dimension mm	Do1=Ds3	Do2=Ds4	Z1 mm	Z2=4 mm	Z3 mm	a °	as °
3067831	110-50-50 x 87.5°	110	50	96	63	37	87,5	90
3074399	110-110-100x87,5°	110	110	145	63	55	87,5	90

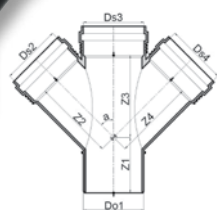

Double Branch

SAP Code	Diameter mm	Do1=Ds3	Do2=Ds4	Z1 mm	Z2=4 mm	Z3 mm	a °
3070908 (*)	50-50-50 x 45°	50	50	69	64	64	45
3070904 (*)	75-50-50 x 45°	75	50	52	87	82	45
3074217 (**)	110-50-50 x 45°	110	50	96	63	37	45
3070907 (*)	110-110-110 x 45°	110	110	78	140	140	45
3070906 (*)	125-110-110 x 45°	125	110	90	147	142	45

(*) It is manufactured from PVC in black color.

(**) It is manufactured as a ready-made garment from PP.

Wavin SiTech B1 / Product Portfolio



Wide Angle Double Branch

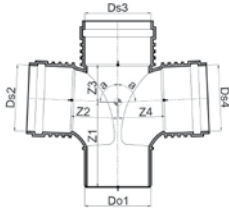

SAP Code	Diameter mm	a °	Do1=Ds3 mm	Ds2=Ds4Z1 mm	Z2=Z4 mm	Z3 mm
3067838	110-110-110 x 87.5°	110	110	144	143	64



Cleaning Part

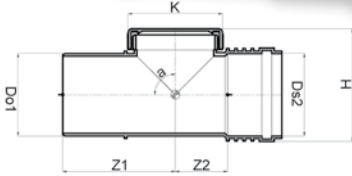

SAP Code	Diameter mm	Do1 mm	Z1 mm	Ds2 mm	Z2 mm	H mm	K mm	a °
3067784	50	50	83	50	36	80	65	90
3067785	75	75	102	75	50	111	93	90
3067787	110	110	135	110	72	155	128	90
3067788	125	125	142	125	74	162	146	90
3074215(*)	160	160	200	160	121	236	141	90

(*) PP Konfeksiyon



Endcap

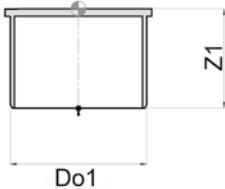

SAP Code	Diameter mm	Z1 mm	Do1 mm
3072439	50	36	50
3072440	75	35	75
3072441	110	39	110
3072442	125	49	125
4047505	160	55	160
4047506(*)	200	60	200

(*) Black colored PP between 50-125 diameters, 160-200 diameters are manufactured from PP in gray color.



ES Siphon - Suitable for Toilet Stone

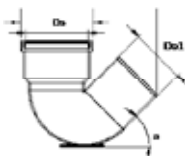

SAP Code	Diameter mm	Do1 mm	Ds mm	Z1 mm	a °	Dirsekli Set Açısı °
3081684(*)	110	45°	125,20	6	45	45°
3081685(*)	110	90°	125,20	6	45	90°

* The product is sold assembled and boxed.



ES Siphon - Pipe Type Muff

SAP Code	Diameter mm	Dirsekli Set Açısı °
3092889 (*)	110	45°
3093920 (*)	110	90°

* The product is sold assembled and boxed.



Wavin System Clamp

SAP Code	Diameter DN
4066449	50
4066450	75
4066452	110
4066453	125
4066454	160
4066455	200

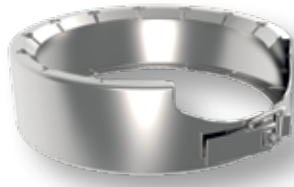

Wavin LKS Metal Clamp

SAP Code	Diameter DN
4065138	50
4065139	70
4065141	100
4065142	125
4065143	150
4065144	200



TÜRKAK - TÜRK AKREDİTASYON KURUMU tarafından akredite
Accredited by TÜRKAK

TSE DENEY ve KALİBRASYON MERKEZİ BAŞKANLIĞI
Makina ve Yapı Malzemeleri Grup Başkanlığı
Yapı Malzemeleri Yangın ve Akustik Laboratuvarı Müdürlüğü

Adres: Aydınlı Mah. Gülennar Sok. No: 7/1 Tarla/ İSTANBUL
Tel: +90 (216) 500 05 27 Fax: +90 (216) 500 05 03 E-posta: yalitim@tse.org.tr Web: www.tse.org.tr

HEADSHIP OF TSE TEST and CALIBRATION CENTER
CONSTRUCTION MATERIALS FIRE AND ACOUSTICS LABORATORY DIRECTORATE

Address: Aydınlı Mah. Gülennar Sok. No: 7/1 Tarla/ İSTANBUL
Tel: +90 (216) 500 05 27 Fax: +90 (216) 500 05 03 E-mail: yalitim@tse.org.tr Web: www.tse.org.tr

MUAYENE VE DENEY RAPORU
TEST REPORT



AB-0001-T
344654
06-17

Deneyi Talep Eden (Adı, Adresi, Şehir vb.)	:	WAVIN TR PLASTİK SANAYİ A.Ş.
Customer Name, Address, City etc.	:	(WAVIN TR PLASTİK SAN. A.Ş. GÜZELEVLER MAHALİNE BULVARI NO:294/A 01310 YÜREĞİR/ADANA Yüreğir-ADANA)
Deney Talep Tarihi/No Order Date / No	:	18.04.2017 / 176825
Namunenin Tanımı (Cins, Marka, Tip, Tür, Model vb.)	:	PLASTİK SU BORUSU, SİTECH , B/BD PVC-U B1 BORU , - , - , 5.00 set
Sample Description (Type, Mark, Model etc.)	:	
Numune Kabul Tarihi Test Item Receipt Date	:	18.04.2017
Deneylerin Yapıldığı Tarih Date of Test	:	10.05.2017 - 29.05.2017
Uygulanan Standard / Metod	:	TS EN 13501-1 + A1:2013-04 Yapı malzemeleri ve yapı elemanları - Yangın sınıflandırması- Bölüm I: Yangın karşısındaki davranış deneylerinden elde edilen veriler kullanılarak sınıflandırma
Applied Standard/Method	:	
Raporun Sayfa Sayısı Number of pages of the report	:	4
Açıklamalar Remarks	:	

Türk Akreditasyon Kurumu (TÜRKAK) deney raporlarının tanınması konusunda Avrupa Akreditasyon Birliği (EA) ve Uluslararası Laboratuvar Akreditasyon Birliği (ILAC) ile karşılıklı tanıma anlaşmasını imzalamıştır.
The Turkish Accreditation Agency (TÜRKAK) is signatory to the multilateral agreements of the European co-operation for the Accreditation (EA) and of the International Laboratory Accreditation (ILAC) for the Mutual recognition of test reports.
Deney ve/veya ölçüm sonuçları, genişletilmiş ölçüm belirsizlikleri (olması halinde) ve deney metodları bu raporun tamamlayıcı kısmı olan takip eden sayfalarda verilmiştir.

The test and/or measurement results, the uncertainties (if applicable) with confidence probability and test methods are given on the following pages which are part of this report.

Bu rapor özel deney talebine istinaden düzenlenmiş olup, Standartlara Uygunluk Belgesi niteliğinde değildir. Partiyi temsil etmez, ayrıca ilan, reklam ve ihalelerde uygunluk belgesi niteliğinde kullanılamaz.

This test report was prepared upon customer's request, can not be used as certificate of conformity to standards, does not represent a batch and can not be used as conformity document for advertisements and procurements.



Deney Sorumlusu
Person in charge of tests
Arda ATAKOL
Uzman Yardımcısı

Kontrol Eden
Reviewer
Sencer GÜVEN
Teknik Şef

Onaylayan
Approved by
Metehan ÇALIŞ
Laboratuvar Müdürü

Bu rapor, hazırlayan laboratuvarın yasal izni olmadan kopyalanıp çoğaltılamaz. İnceleme ve müdahale raporlar geçersizdir.
Bu rapor, sadece deneyi yapılan numune için geçerlidir ve "Örüm Belgesi" yerine geçmez.
This test report shall not be reproduced other than in full except with the written permission of the laboratory. Test reports without signature and seal are not valid.
This test report represents only tested samples, and shall not be used as Product Certificate.

L:38-D:38-36 01.02.2016-1

1/4

Discover our broad portfolio at www.wavin.com.tr

- Hot&Cold Water
- Indoor Climate Solutions
- Urban Climate Resilience
- Waste Water Solutions
- Potable Water Pipeline
- Stormwater Management
- Sewer System Solutions



wavin

orbis

Wavin is part of Orbis, a community of companies working together to tackle some of the world's most complex challenges.

We are bound by a common purpose:
To Advance Life Around the World.

Wavin TR Plastik Sanayi A.Ş. | Güzelevler Mah.Girne Bulvarı No: 294/A Yüreğir / Adana
Web www.wavin.com.tr | E-mail wavin.tr.info@wavin.com

Wavin operates a programme of continuous product development, and therefore reserves the right to modify or amend the specification of their products without notice. All information in this publication is given in good faith, and believed to be correct at the time of going to press. However, no responsibility can be accepted for any errors, omissions or incorrect assumptions.

© 2022 Wavin | Wavin reserves the right to make alterations without prior notice. Due to continuous product development, changes in technical specifications may change. Installation must comply with the installation instructions.